

Wireless World

VOL. LVI. No. 2.

FEBRUARY, 1950

Growth of Television

THE new B.B.C. television transmitter at Sutton Coldfield may now fairly be hailed as a success, and everyone concerned with its design and construction is to be congratulated. The initial breakdowns may, it is fair to assume, be attributed largely to the initial difficulties that might reasonably be expected to arise from the high power of the transmitter—the highest power yet used for television and, indeed, exceptionally high power for any form of e.h.f. transmitter on comparable frequencies. Range has proved to be considerably greater than early official estimates would suggest and, over the densely populated area immediately surrounding the station, signal strength is so tremendous that good pictures are receivable on the simplest and cheapest installations. The method of feeding picture modulation to the transmitter by means of a radio link has proved entirely successful, and viewers in the Midlands are under no disadvantage as compared with those around London: there is certainly no detectable deterioration as a result of relaying.

On the broader issue, much encouragement can be taken from this first step in spreading television over the whole country. The basic standards chosen for our system, the method of distributing a single programme and the relatively austere nature of our projected national service all fit in well with the present economic position. Receivers for our medium-definition system can be manufactured at a price which brings them into the mass market—an essential for the growth of television—while the radio-frequency bandwidths required are of reasonable width, thus simplifying at least some of the problems of distribution.

There has been some dissatisfaction at the tardiness of putting into effect this first step in serving the provinces with television. Now that the ice has been broken, we hope development will proceed in a rapid and orderly manner—just as fast as sets for would-be viewers can be made and ancillary requirements—such as the training of technicians for installation and maintenance—can be met.

Vicissitudes of "Electronics"

A CONTROVERSY has arisen in the U.S.A. on the origin of the word "electronics" and also of its adjective, "electronic," and it is suggested there that the former word was used in England long before 1929, which is the critical date for the American discussion.

This is an argument to which we find it difficult to contribute anything helpful to the participants. There is no doubt that Johnstone Stoney in the last century coined the word "electron" to describe an elementary electrical particle; it seems safe enough to guess that "electronic" appeared soon afterwards as the adjectival form. It is rather less safe to guess, though it is possibly true, that at about the same time the word "electronics" was used to describe the science of electricity according to the electron theory.

But all this does not get us much further, as we cannot trace in this country any early use of the

word "electronics" in the restricted sense rather arbitrarily later ascribed to it somewhere. The official American definition nowadays is "that branch of science and technology which relates to the conduction of electricity through gases or *in vacuo*."

We are interested to see that the Americans confine their controversy to the origin of the word; happier than us, they seem to be in no doubt as to what it means. Here, we regret to observe, it tends to become rather meaningless, and, unless we are careful, will become just another catchword like "streamlined." Perhaps the most popular definition of "electronics" at the moment is "radio techniques as applied to non-communication uses," but there are plenty of others. Perhaps that is why wise practitioners in the art now tend to be shy of the word, restricting its use to contexts where they feel the meaning will be clear.

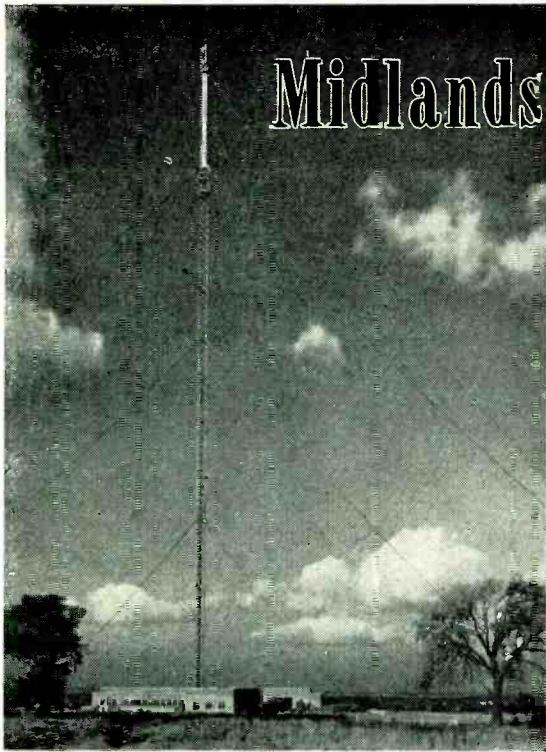

The 750-ft mast of the Sutton Coldfield station carries eight dipoles at the extreme top which radiate both sound and vision. The lower tubular section, between the dipoles and the lattice structure is a "slot" radiator intended for future v.h.f. broadcasting.

Television Station

Details of the New Transmitter

THE Sutton Coldfield television transmitter, which was officially opened on 17th December, has a peak power of 35 kW and is claimed to be the largest in the world. Situated about eight miles north of Birmingham the station is some 500 ft above sea level and is provided with a 750-ft mast to bring the aerial system 1,250 ft above sea level.

The mast is of triangular section with 9-ft sides for the first 610 ft. Above this it is circular for another 100 ft and this part contains a slot aerial system intended for future v.h.f. broadcasting. The television aerials are higher still and comprise eight folded dipoles arranged in two tiers of four each. All dipoles are common to both sound and vision channels.

A lift is provided in the mast up to 610-ft level. In order to permit angular movement in wind the mast rests on a steel ball and is supported by four sets of stays. It was designed and constructed by British Insulated Callender's Construction Co., and the topmast and aerials were made by Marconi's W. T. Company.

The separate transmitters for sound and vision together with their ancillary equipment are contained in a single-storey building. The sound transmitter, by Marconi's W.T. Company, is of 12-kW average carrier power output at 58.25 Mc/s with class B anode modulation of the output stage. The drive unit is followed by three push-pull amplifier stages. The final stage is a single BR128 valve in an earthed-grid coaxial-type circuit, the output being fed through a concentric feeder to the aerials. Air cooling is used for the valves.

The vision transmitter provides up to 35 kW peak power with a carrier frequency of 61.75 Mc/s. It was constructed jointly by E.M.I. and Metropolitan-Vickers, the latter firm being the sub-contractors for the major part of the radio-frequency equipment. On the r.f. side the transmitter starts with an r.f. drive unit, supplied by Marconi's W.T. Company, similar to that used for the sound channel; it contains a crystal oscillator and two stages of frequency multiplication. This is followed by a three-stage low-power amplifier beginning with a single-valve pentode followed by a push-pull tetrode stage and ending with a pair of triodes in push-pull in the earthed-grid connection.

The driver stage, following this, has two ACT26 triodes operating as a class C neutralized push-pull amplifier. The final stage uses CAT21 triodes in an earthed-grid circuit with parallel-line circuit elements and it feeds the output coaxial-line feeder. This stage is grid modulated

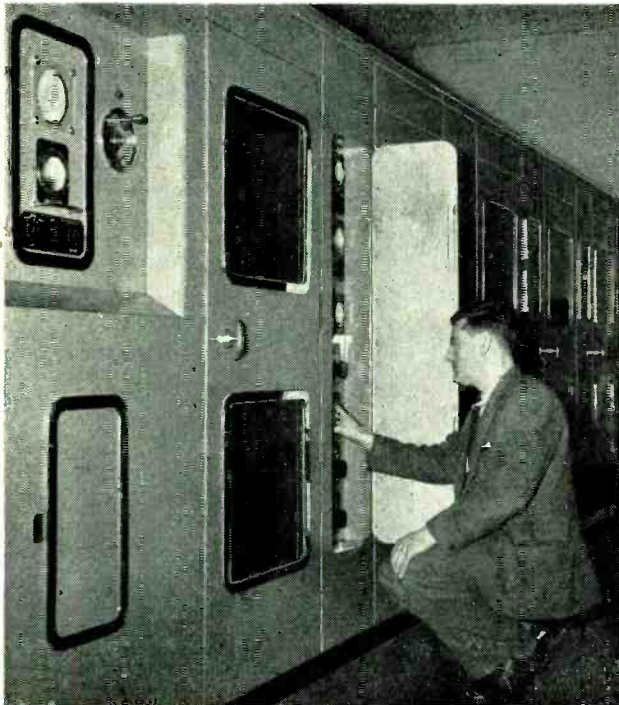

This photograph shows the r.f. side of the vision transmitter with the waveform monitor in the foreground. The power supply is in a room immediately behind the transmitter.

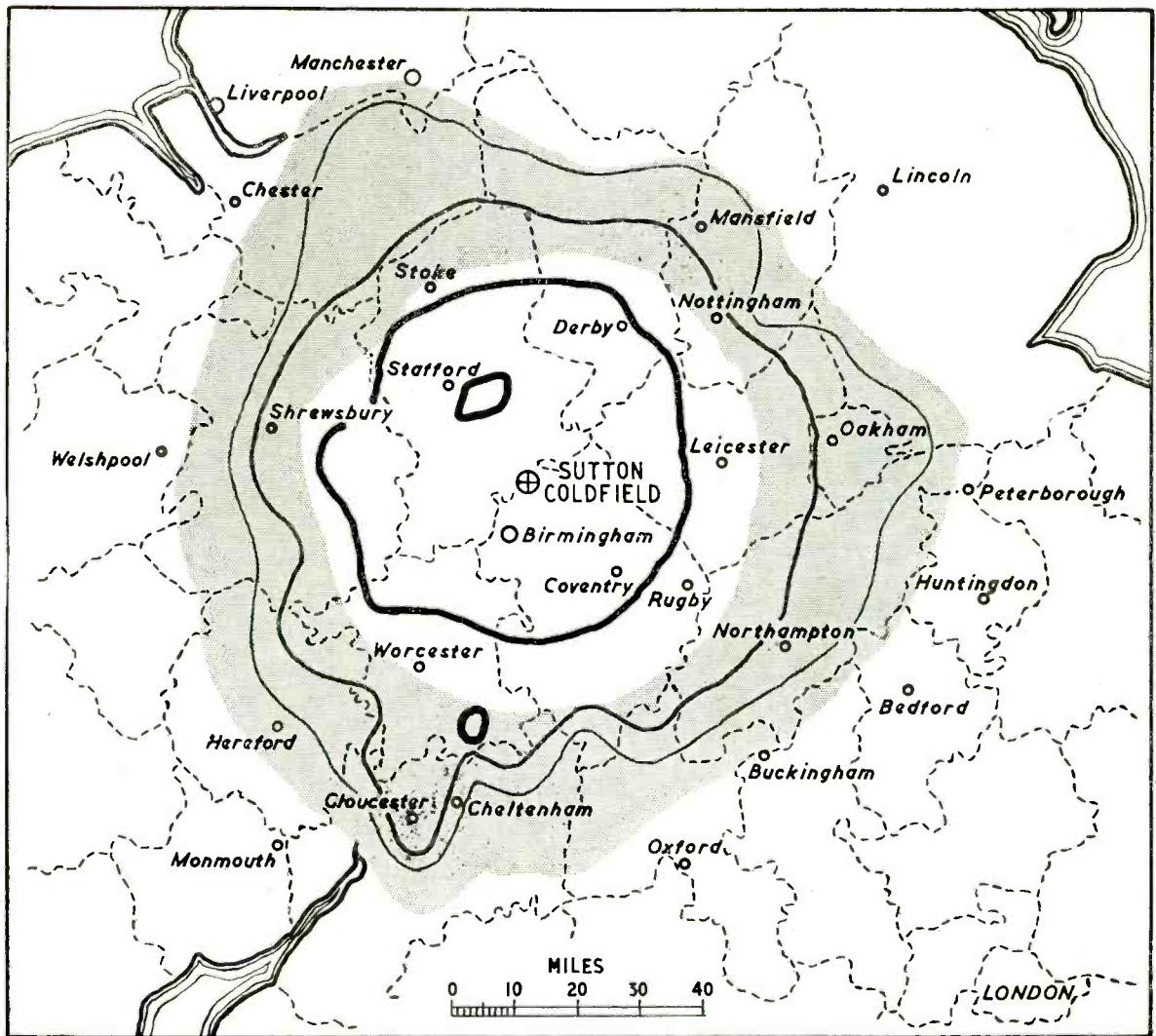

This map of the service area of the Sutton Coldfield transmitter is based on calculation and indicates the strength of signal to be expected on theoretical grounds. The heavy contours are for field strengths of 5 mV/m, the medium 500 μ V/m, and the light 100 μ V/m; the figures are for peak-white transmission and a receiving aerial 30 ft above ground. In the shaded zone satisfactory reception will be subject to favourable local conditions and some fading may be experienced at times; beyond the shaded zone consistent reception cannot be expected. The service area which will actually be obtained cannot be known until the station has been in operation for some months, but the preliminary reports during the first weeks indicate that it is likely to be much greater than this map depicts.

by the vision signal. This final stage is water cooled, but the others are all air cooled.

The vision signal enters the station through a cable link by which it is conveyed from the terminal station (in Birmingham) of the London-Birmingham radio link. The signal has an amplitude of about 1 V and is applied to a pre-amplifier which is arranged to have an adjustable curvature of its input/output characteristic. This amplifier also enables the relative amplitudes of the picture signal and the sync pulses to be controlled.

Further amplifiers are designated the sub-sub-modulator and the sub-modulator, a black-level clamp being provided between the two. The modulator is a cathode follower using four valves in parallel. It gives no voltage amplification, but has a

sufficient power output at very low impedance to supply the 3.5-A grid current of the final r.f. stage as well as the large capacitive current which it demands. ACM₃ valves are used throughout the modulators and are air-cooled.

The transmitter output is taken through a coaxial line to the vestigial-sideband filter. It is of the constant-resistance type and includes a high-pass and a low-pass section constructed of coaxial line. The output of the l.p. section is taken through a coaxial line to the aerial, this line forming the termination of the filter. The high-pass section, however, is terminated by a water load in which the power of the unwanted sidebands is absorbed.

The filter transmits the lower-frequency sidebands to the aerial but increasingly attenuates the upper

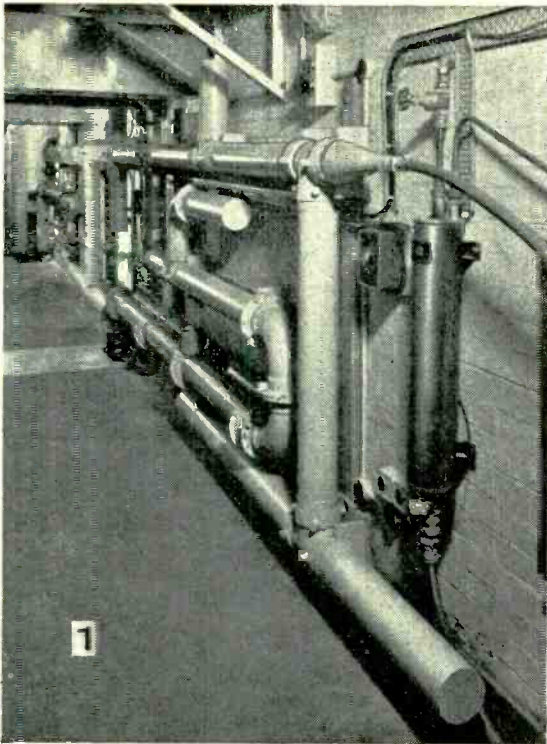

(1) The vertical-sideband filter is of the constant-resistance type with high- and low-pass sections. It is constructed of coaxial lines and the power from the unwanted sidebands is absorbed in a "water load."

sidebands for vision frequencies above 0.75 Mc/s. At 63.25 Mc/s, the sound channel of an adjacent future television station, the attenuation is 12 db.

The r.f. outputs from the two transmitters are taken up the mast in separate coaxial feeders. They are of 5-in outside diameter and 51- Ω impedance. They are made in 12-ft sections and expansion joints are fitted every 150 ft to allow for temperature changes. Dry air is blown continuously through them to prevent condensation. In order to facilitate adjustment and testing, the vision transmitter output can be switched to a water load in which the power is then dissipated and measured.

Towards the top of the mast the feeders terminate in a diplexer. This is a device which combines the sound and vision signals and at the same time prevents power from one feeder from being fed down the other. It is the equivalent of the hybrid transformer so widely used in a.f. lines technique.

The combined signals in the output of the diplexer are taken through feeders to a pair of unbalance-to-balance transformers and thence by two pairs of coaxial feeders to the aerials. One pair feeds the north-south dipoles in each tier and the other the east-west dipoles.

The Aerials

Phase shifts are introduced into the dipole feeds and in the opposite sense for the sound and vision signals. Clockwise from north the vision signal in both tiers is phased 0°, 90°, 180°, 270°, while the sound is phased 0°, 270°, 180°, 90°. The aerial gain in a horizontal plane is 4 db. The dipoles themselves are made from 10-in galvanized steel strip; 7.5-kW heaters are fitted to prevent ice formation.

(2) The photo on the left shows the interior of the final stage of the vision transmitter. The vertical tubes form the anode tuning inductances and are mounted below the CAT21 valves. The output circuit tuning capacitors are visible in the front above the output feeder. The photo on the right shows the control desk for the sound and vision transmitters; it includes a c.r. wave-form monitor tube. Picture-monitor tubes are provided and the control room has windows looking into the transmitter hall.

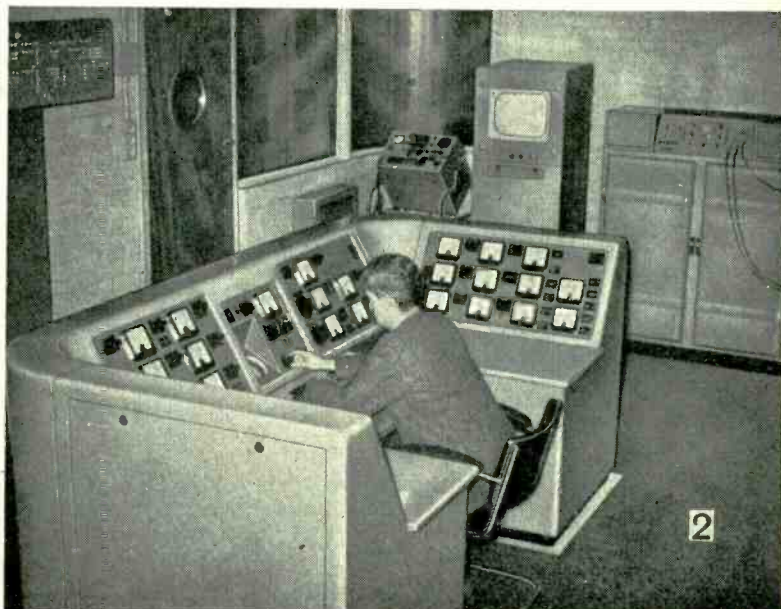
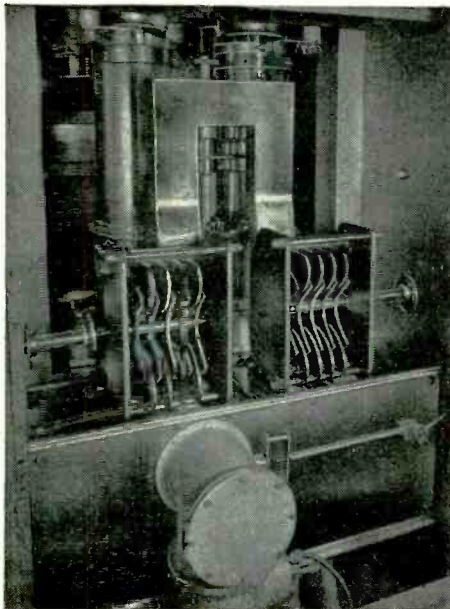

The transmitting equipment is rack-mounted and the racks are assembled in line against one wall of the transmitter hall. On the other side of this wall the power-supply apparatus is fitted, the connections passing through the wall and being consequently quite short. Hot-cathode mercury-vapour rectifiers are used for the vision transmitter and the supply at 415-V 3-phase is stabilized and phase-balanced by three moving-coil voltage regulators. The smoothing circuit for the final stage is built out to a low constant resistance and the high-voltage anode supplies for the other stages have valve stabilizers.

Voltage Control

A.C. heating is used for the valve filaments except in the modulated stage, where a d.c. supply from a motor generator is used. An electronic regulator is employed to keep the voltage within 0.1 per cent of its nominal value. The power is derived from the grid system at 11 kV and transformed to the 415-V used in the building. An emergency lighting system at 240 V from batteries is provided.

The equipment for cooling is located between the two power-supply rooms for the sound and vision transmitters. The heated air can be switched into the main building for space heating in winter.

Looking into the transmitter hall is the control room in which a control desk enables one man to operate both transmitters. In addition to meters, a c.r. tube is provided as a waveform monitor and there are picture monitor tubes to show both the incoming signal and the radiated signal. A diagram with 200 miniature lamps provides a tell-tale; the lamps light in turn as the supplies to each stage are established.

The station contains no studio since it is intended to be fed normally by a picture originating in London. When local programmes are required the standard outside-broadcast equipment is to be used. A film-scanner is provided, however, and its purpose is mainly to provide a source of programme in the event of a breakdown in the link to London.

ITALIAN TELEVISION TESTS

WE learn from our Italian contemporary *Elettronica and Televisione* that tests have recently been concluded in Italy with both French and American television equipment preparatory to starting a service. The transmitters were erected by the Italian broadcasting authority on a 700-metre hill in the vicinity of Turin and receivers were installed in public buildings in a number of towns.

The American equipment, which operated on 83.25 Mc/s (vision) and 87.75 Mc/s (sound), was built to U.S. standards—with negative modulation and the lower sideband suppressed—except that the scanning rate was 625 lines with 25 frames instead of 525 with 30 frames. Sound was frequency modulated. The French transmitter employed the new 819-line standards of the projected French system.

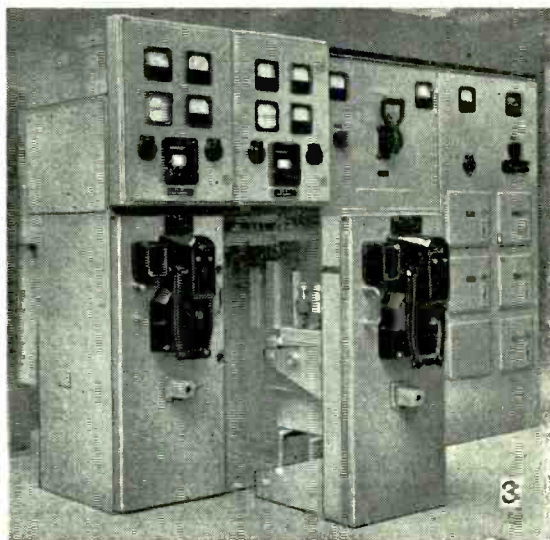

(3) Power switchgear for the transmitters supplied by Brush Electrical Engineering.

(4) The cooling plant is shown in this photo. On the left is part of the water-cooling equipment for the final stage of the vision transmitter. The other valves are air-cooled and the heated air can be utilized, if required, for heating the building.

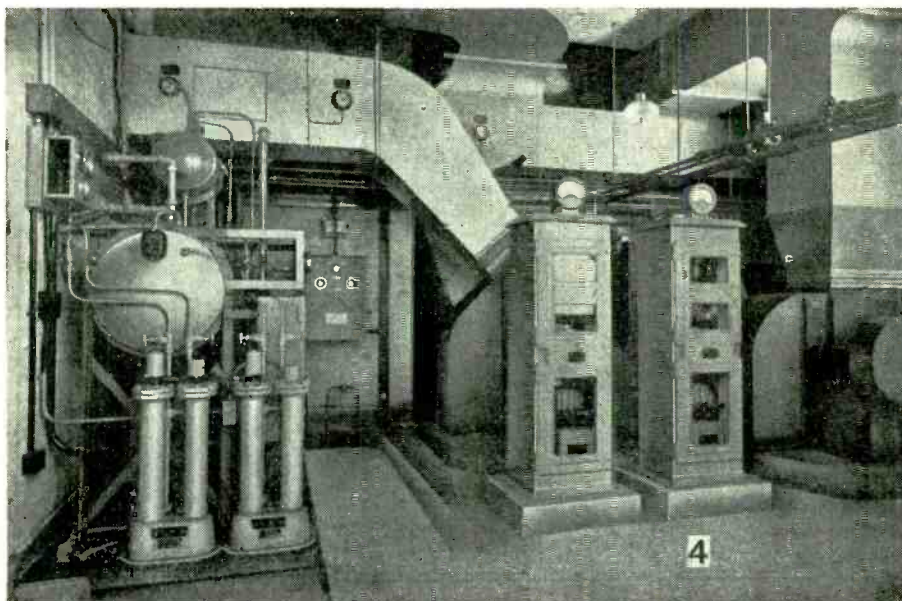

New Sub-miniature Valves

"Flat" Types with Filaments Drawing Only 15mA

By C. C. GEE (Mullard Electronic Products)

IN the March, 1948, issue of *Wireless World* an account was given of a series of 10-mm sub-miniature valves which were specially developed by Mullard for use in the National Health Hearing Aid, "Medresco." These valves, which had 25-mA filaments, compared favourably in performance with corresponding valves of American manufacture, and fully met the requirements of the specification laid down by the Post Office Research Station. However, from the very onset of the development of these valves there was a pressing demand for still smaller types, of flat construction, having even lower filament currents.

The new series of flat sub-miniatures, represented by the Mullard voltage-amplifying pentode DF66, and the output pentode DL66, meet this demand, and mark a notable advance in valves specifically designed for hearing aids. As a result of this development, it will be possible to reduce still further the size and weight of these instruments, and at the same time extend the life of the batteries. It is claimed that the new valves will not only satisfy the requirements of manufacturers of hearing aids in this country, but will also be able to compete on very favourable terms with American types in the world market.

Some idea of the rapid progress that has been made in the development of hearing aid valves during the past thirteen years may be gathered from Table I. From the table it will be seen that the volume of the new voltage-amplifying sub-miniature DF66 is

TABLE I

	DA1 Voltage-amplifying triode	DC51 Voltage-amplifying triode	DF70 Voltage-amplifying triode	DF66 Voltage-amplifying triode
Year introduced ...	1936	1939	1947	1949
Overall length (mm) (in)	60 2.36	62 2.44	29.5 1.16	27 1.06
Overall dia. or (mm) cross-section (in)	19 0.74	17 0.66	10 0.39	8.3 × 6.1 0.32 × 0.24
Volume ... (mm ³) (in ³)	17,000 1.04	14,100 0.87	2,320 0.141	1,400 0.085
Cross-sectional area. (mm ²) (in ²)	280 0.43	225 0.34	78 0.12	52 0.08
Filament current (mA) ...	50	67	25	15

The Mullard type DF66 valve fitted into a standard sub-miniature holder.

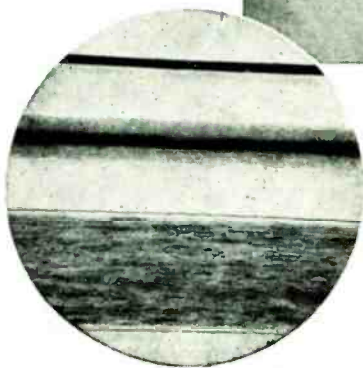

Uncoated and coated filament of the Mullard DF66 flat sub-miniature valves compared with a human hair.

less than one-twelfth that of the Mullard DA1, introduced in 1936; moreover, the filament current has been reduced from 50mA to 15mA. Comparing the DF66 with its equivalent 10-mm type, DF70, it will also be noted that not only has the volume been reduced but, as a result of the flat type of construction, there has been a marked reduction in the cross-sectional area. The importance of this in the design of extremely compact hearing aids may be judged from the fact that the total cross-sectional area enclosed by three of the new valves is only 156 sq mm (0.24 sq in) as against 234 sq mm (0.36 sq in) for three of the 10-mm type sub-miniatures. This results in approximately a two-thirds saving in space. Three of the latest flat-type American valves similarly placed enclose a cross-sectional area of 213 sq mm (0.33 sq in). This means that the space saved by using the new British valves in place of equivalent American types amounts to over a quarter.

Filament Diameter

The low filament current of the new valves has been obtained through the use of highly emissive, oxide-coated filaments, having a tungsten core of no more than 7.8 microns (3/10,000th in) diameter. The remarkable precision of the tungsten wire and the uniformity of the oxide coating is apparent from the photograph, which shows the coated and uncoated filaments scaled against a human hair. From this it is estimated that the tungsten wire is less than

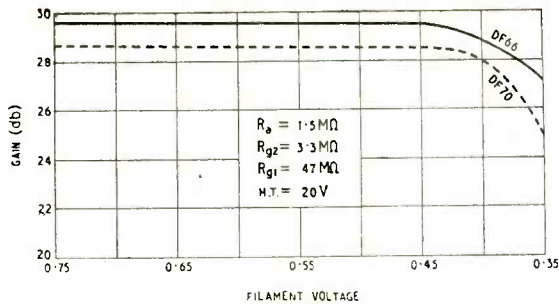

Typical curves showing gain in relation to filament voltage for the DF70 and DF66 type valves.

1/10th as thick as the hair, whilst the coated filament is less than 1/3rd as thick.

In spite of the extreme fineness of the filament wire, it has been found possible to produce the filaments on a mass-production basis on conventional filament-making machines. During all stages of manufacture, every precaution is taken to ensure the highest possible standards of purity and surface smoothness of the wire. Extreme care is also taken in the coating of the wire, in order to ensure stable emission.

Sealing Technique

The special sealing technique employed in the production of these valves is such that the heat is directed away from the electrode assembly during the sealing process. In this way the problem of electrode poisoning and distortion is largely overcome. It is this sealing technique which makes possible the use of extremely fine filaments. Since in this method the envelopes are sealed directly to the glass bases, it has also been possible to reduce the length of the valves.

Another important feature is freedom from microphony. This has been achieved by reducing the length of the electrode system and improving the methods of springing. As a result of this the fundamental frequency of the filament of the DF66 has been raised to about 6,000 c/s. This is far above the upper frequency limit of 4,000 c/s specified for most hearing aids at present in use.

The lead-out wires in these valves may be either soldered directly to the circuit components, or may be cut back to about 1/4 in, and fitted into standard sub-miniature sockets as shown in the photograph.

It would normally be expected that the reduction in filament current from 25 mA to 15 mA, which has been achieved in these new valves, would result in a considerable reduction in the gain. This, however, has been offset by a marked improvement in the design of the grids. By using fine wire and by taking extreme care in the symmetry of the electrode assembly, it has, in fact, been possible to improve the gain of the DF66 voltage amplifier by one or two db compared with the 10-mm type DF70. Moreover, as shown by the gain curves, the fall of the gain with decreases in the filament voltage is not quite so rapid in the DF66. This means that even when the voltage of the l.t. battery is reduced from its normal 1.25 V to 0.8 V the response of the hearing aid circuit can be maintained at a reasonably high level.

On account of their small size and low filament current, these new valves should prove of particular value in the design of hearing aids in which both the l.t. and h.t. batteries are housed in the case of the instrument. It is estimated that instruments of this kind having a nominal output of about 2.5 mW should meet the requirements of over 70 per cent of those suffering from defective hearing. Using two DF66 voltage-amplifying pentodes in series, feeding into a single DL66 output pentode, it should be possible to produce hearing aids weighing less than 5 ounces. These could be easily concealed about the person of the wearer, so as to be almost undetectable. By using l.t. cells of the mercury type, it is probable that such instruments would give over 50 hours of useful service before it is necessary to replace the l.t. battery. A similar instrument embodying one of the ordinary leclanché-type cells should give over 12 hours of continuous use.

With the introduction of these new flat sub-miniatures it appears that the reduction in size of valves of this class has almost reached its limit. Future developments will possibly be in the direction of even lower filament currents and higher gains. As a result of these improvements it should be possible to extend still further the life of hearing aid batteries, or, conversely, reduce their size for a given life period. It will be realized that this is the most practical way of designing smaller lightweight hearing aids when it is considered that, in such instruments, it is the batteries which account for a large percentage of the size and weight.

It is interesting to note that, parallel with this development, Mullard are bringing out a complete range of both battery and mains 10-mm sub-miniatures for use in miniature communication equipments, and other compact, lightweight electronic units.

TABLE II

Principal Characteristics Compared

	10-mm Sub-miniatures		Flat Sub-miniatures	
	DF70 Voltage-amplifying pentode	DL71 Output pentode	DF66 Voltage-amplifying pentode	DL66 Output pentode
V_f (V)	0.625	1.25	0.625	1.25
I_f (mA)	25	25	15	15
V_a (V)	30	45	22.5	22.5
V_{g2} (V)	30	45	22.5	22.5
V_{g1} (V)	0	-1.25	-1.05	-1.4
I_a (mA)	0.375	0.6	0.05	0.3
I_{g2} (mA)	0.125	0.15	0.015	0.075
g_m mA/V	0.22	0.55	0.1	0.35
$P_{out}(10\% \text{ distortion})$ (mW)	—	6	—	2.5

Output Impedance Control

Variable Loudspeaker Damping Without Alteration of Output Level

By THOMAS RODDAM

WHENEVER the Editor feels rather lonely in his eyrie overlooking the South Bank, and wants readers to write to him, he publishes an article on the loudspeaker damping problem. As the best "damping factor" depends on the loudspeaker design, letters pour in, and he feels that it must be Christmas again. Although no one seems to have used this simile, the choice of a damping factor is very much like the adjustment of a swing door: with too little damping the door swings to and fro several times after it is released; with too much damping it shuts very slowly, leaving a most unfriendly draught blowing for some seconds after each person comes in. The loudspeaker cone behaves in the same way: too little damping and it oscillates on its own whenever it receives a shock; too much, and transients are lost completely. At this point the usual thing is to jump in and quote a magic figure for damping factor, which will solve all problems. I don't propose to do this, because I'm pretty certain that all types of loudspeaker require different answers. Some, I suggest, are like galvanometers I have encountered, and need negative resistance to provide critical damping.

The obvious thing to do is to change the damping factor until it sounds right. There are rather more complicated ways of checking the damping factor, but if you can't hear the difference, why worry; your friends won't be impressed. In this article I shall show how an amplifier can be constructed with a variable output impedance, with the rather important feature that as you vary the impedance the output stays the same. You can alter the impedance with a signal on and listen to the effect, without any disturbing level changes or distortion: the distortion actually varies slightly, but it is low enough to be disregarded anyway. The impedance can be brought right down to zero, or even made negative, but of course if the negative output impedance is bigger than the load the amplifier becomes an oscillator:

this effect is easily detected by the pragmatic test: you can hear it!

I shall assume that the reader has a file of back numbers of *Wireless World* and that before he goes any further he will read "Cathode Ray's" article in the February 1946 issue. In this, the effect of negative feedback on the output impedance of the amplifier is explained. Summarizing, negative voltage feedback reduces the output impedance, while negative current feedback increases it. By applying the reasoning which leads to these results it is easy to show that positive current feedback will reduce the output impedance. We therefore have two ways of reducing the impedance, one of which, negative feedback, is very commonly used. Within certain limits we could use only negative feedback, but the disadvantage for our present purpose is that as we alter the feedback we alter the overall gain of the amplifier. This does no harm if we are adjusting the circuit once for all, but if we are studying the way different damping factors sound, it is not desirable to have to adjust the level each time we change the impedance. In addition, we are restricted in the range over which the impedance can be adjusted.

Writing A for the voltage amplification without negative feedback, and B for the fraction of the output voltage fed back, the gain of the amplifier is $A/(1 + AB)$ with feedback. So long as A is large we can take $(1 + AB) \approx AB$, and the gain as just $1/B$. This is a good approximation in most practical cases: for example, in a two-stage amplifier we may have $A = 1,000$ and $B = 1/100$, giving $AB = 10$. The voltage amplification is then exactly 90.1 , or approximately 100 , a difference of only 0.9 db. If A increases to $4,000$, the gain increases to 97.7 times, or by 0.7 db. Thus by using enough feedback to reduce the gain 20 db we keep the gain constant within $\pm \frac{1}{2}$ db however we increase A .

We can make use of this by applying negative

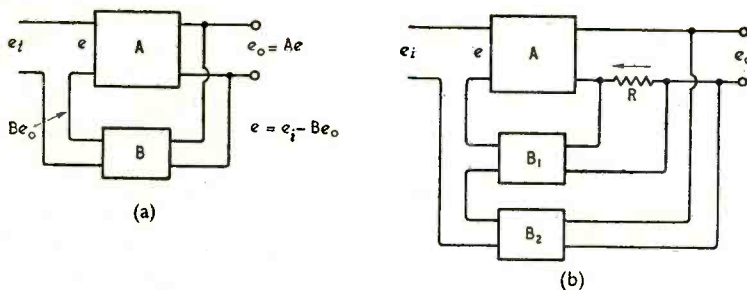
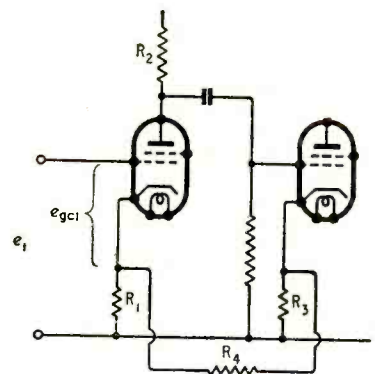

Fig. 1. (a) Normal connections in a negative voltage feedback amplifier. (b) Mixed voltage and current feedback. Fig. 2. (right) Basic positive feedback circuit.



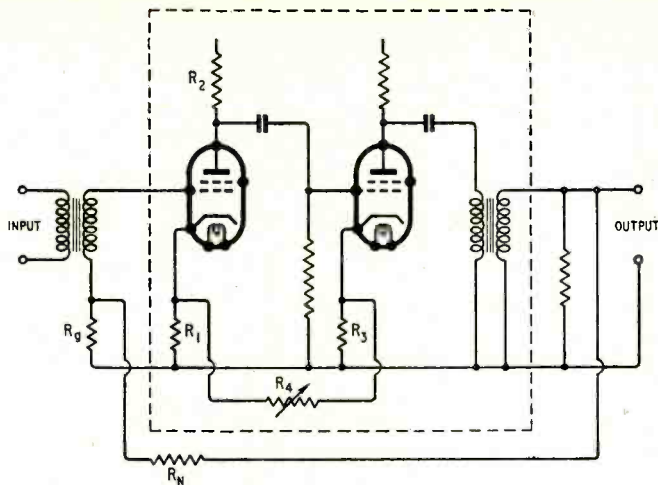

Fig. 3. Combined feedback circuit of amplifier with variable output impedance. R_4 is the control; suitable values are suggested in the text.

feedback round the whole amplifier, and at the same time putting positive current feedback round an inner loop. Fig. 1 shows a normal negative voltage feedback amplifier and an amplifier having two feedback paths, B_1 for current feedback and B_2 for voltage feedback. For this amplifier the input voltage e will be $e_i + B_1 i R - B_2 e_o$, where B_1 is the positive current feedback path and B_2 the negative voltage feedback path. I shall not develop the equations, because this particular arrangement is easily seen to be inconvenient as soon as earths are to be applied to the circuit. Instead, let us consider the circuits of Fig. 2.

Design Relationships

In this two-stage pentode amplifier, the first valve has a mutual conductance g_1 , and the second g_2 . The current in the anode load of the first valve will be $g_1 e_{gc1}$, producing a voltage at the grid of the second valve equal to $-g_1 e_{gc1} R_2$. For this valve, we have

$$e_{gc2} = -g_1 e_{gc1} R_2 - g_2 e_{gc2} R_3 \text{ giving}$$

$$e_{gc2} = -\frac{g_1 e_{gc1} R_2}{1 + g_2 R_3}$$

Across the cathode load R_3 we have a voltage $g_2 e_{gc2} R_3$, of which a fraction $R_1/(R_1 + R_4)$ appears across the cathode resistance of the first valve, so long as R_4 is much larger than R_2 . The input voltage e_1 required to produce the grid-cathode voltage e_{gc1} is therefore

$$e_1 = e_{gc1} + e_{gc1} g_1 R_1 - \frac{R_1}{R_1 + R_4} \cdot \frac{g_1 e_{gc1} R_2}{1 + g_2 R_3}$$

We can have a finite value of e_{gc1} for $e_1 = 0$ by making

$$1 + g_1 R_1 = \frac{R_1}{R_1 + R_4} \cdot \frac{g_1 R_2}{1 + g_2 R_3}$$

This means that we have infinite gain, which is the condition for zero impedance to appear at the anode of V_2 . To simplify this expression, let us take $g_1 = g_2$, $R_1 = R_3$ and $g_1 R_1 = g_2 R_3 = 1$, with $g_1 R_2 = 100$.

Then

$$\frac{R_4}{R_1} + 1 = \frac{1}{2} \cdot \frac{100}{2} = 25$$

or $R_4 = 24 R_1$

Now let us look at Fig. 3. If this is compared with the top diagram in Fig. 1 it will be seen that the circuit inside the dotted box is simply an amplifier A, and the B circuit is now R_g and R_N , with a value of $B = R_g/(R_g + R_N)$ or $\approx R_g/R_N$. As we saw, we can increase the gain A inside the box as much as we like without affecting the overall gain, which stays very close to $R_N/R_g = 1/B$. (The gain due to the input transformer is neglected at the moment). We are therefore free to alter R_1 , which alters the output impedance, without altering the overall level, unless, of course, we make the circuit unstable. If we fix a minimum value of R_4 at about 20 times R_1 we can

persuade the output impedance to go just negative, and by increasing R_4 we can produce a range of output impedances up to a maximum of $[\gamma_a/(1 + AB)] \sqrt{n}$ where γ_a is the anode impedance of the valve and n is the output transformer ratio.

At this point I feel a certain diffidence. My landlord occupies the flat above me, and the temptation to build one of those nice 100-watt audio amplifiers has always been sternly repressed. In fact, as I write the loudspeaker is operating at a pleasant 50 mW. My work on this variable-impedance amplifier has been based on a 1-watt output level, using a single-sided amplifier. The valves used were a 6J7 and a 6L6, because the foreign customer to whom the equipment is to be sold refuses to be committed to valves from one particular maker. He hasn't any dollars, but by using American types he can get a much wider choice of suppliers than if he has valves on the British Spring 1949 base which will go out of fashion sooner than did the New Look. With these valves, R_2 in Fig. 3 was 33 k Ω , R_1 620 Ω , R_3 220 Ω , and R_4 a 100-k Ω variable resistor. No trouble was experienced due to small bias changes caused by the d.c. which flows through R_4 . With this circuit an output impedance of less than one-tenth of the load impedance was easily obtained.

There is another use for this circuit. If you like having the same programme in all the rooms in your house, if you have a house and can't make one speaker heard all through it, this low impedance amplifier is very useful. By feeding a line from a very low-impedance amplifier, additional loudspeakers can be added without altering the level at those already connected. Obviously the amplifier must have sufficient power available to drive the maximum number of loudspeakers, but if this is so the amplifier adjusts itself to deliver constant voltage irrespective of the load.

Examination of the Williamson amplifier circuit (Aug. 1949 issue) suggests that it should be possible to apply positive feedback from V_5 to V_3 and from V_6 to V_4 . This involves splitting R_{10} into two 780-ohm resistors, and R_{22} into two 300-ohm resistors. Equal amounts of feedback must be provided, but readers who have constructed this amplifier may find the experiment of interest.

TEST REPORT

Denco Model DCR19

Communications Receiver Embodying a Coil Turret and Crystal Calibrator

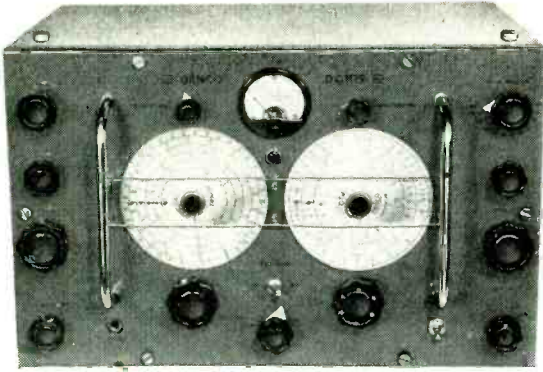

General view of the DCR19 receiver showing layout of the front panel. The left-hand scale is for bandspread, the right-hand one carries the six main scales.

ONE of the distinctive features of the Denco DCR19 communications receiver is the use of a rotary coil turret which removes all the idle coils from the circuit and short circuits any that might act as absorbers for those in use. The turret is particularly well made and all coils are wound on polystyrene formers and have air-spaced trimmers.

Embodied in the coil unit is a mechanical bandspread tuning system which enables a small part of any of the six wavebands to be expanded for ease of tuning, it also enables very accurate measurement of the received stations' frequency to be made. For this purpose a 500-kc/s crystal calibrating oscillator is used.

The six wavebands provided by this receiver have respective coverages of the following frequencies:—

- 175 to 525 kc/s
- 515 to 1,545 kc/s
- 1.65 to 5.0 Mc/s
- 4.8 to 9.6 Mc/s
- 9.4 to 18.8 Mc/s
- 18.0 to 36.0 Mc/s

The parts selected for bandspreading are the five amateur wavebands as follows:—

- 3.5 to 3.8 Mc/s
- 7.0 to 7.4 Mc/s
- 14.0 to 14.8 Mc/s
- 21.0 to 21.8 Mc/s
- 28.0 to 29.8 Mc/s

Inclusion of the 21-Mc/s band is in anticipation of its release as it is not yet allotted for amateur use in this country. These bandspread selections would indicate that the receiver is largely intended for the amateur market both here and overseas. The inclusion

of a power outlet socket at the back of the set for operating a converter, presumably of the v.h.f. variety, also lends weight to this assumption. In any case, it is a useful feature as it gives access to a 6-volt a.c. supply and to the h.t. on-off switch connections so that a relay could be fitted externally to the set and operated from a remote point if needed.

An examination of the specification reveals that the unusually high intermediate frequency of 1.6 Mc/s is used. This choice undoubtedly assists image signal rejection and enables one r.f. stage to suffice for all bands. For this an EF91 valve is used, and in view of the high efficiency of the wave-change system and of the coils quite a high gain is given by this single stage.

High intermediate frequencies have their disadvantages as well as advantages, but the only one of any consequence is the need to employ a few more tuned circuits in order to obtain adequate adjacent channel selectivity. In the DCR19 there are eight circuits distributed between three i.f. amplifying stages using 9D6 valves. Together they give a maximum bandwidth of 8 kc/s.

There are, all told, five different bandwidths available; the 8-kc/s one already mentioned, 8 kc/s plus

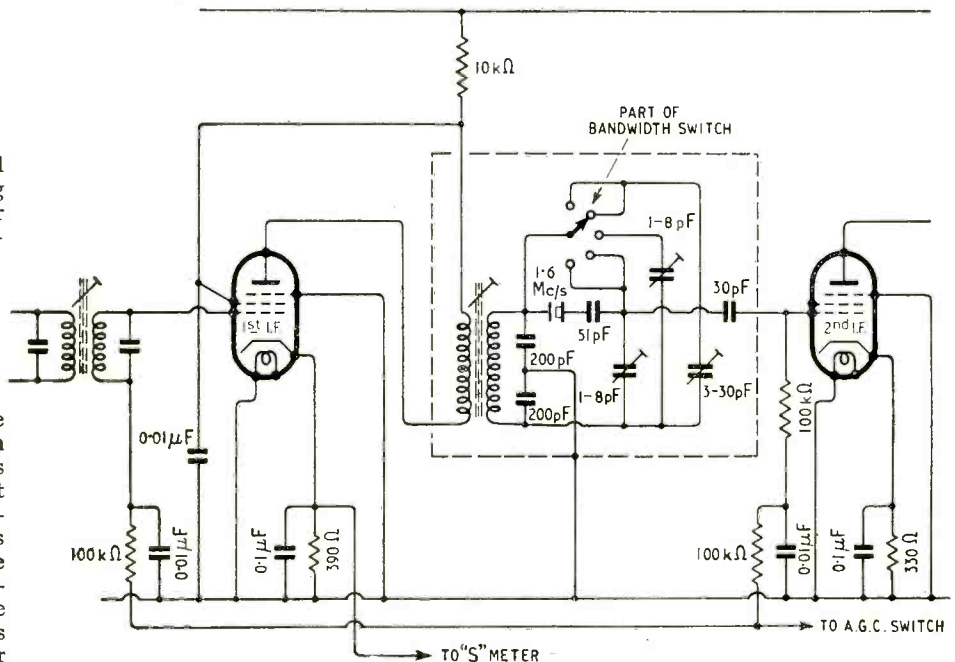

Circuit details of the inter-stage coupling following the first i.f. valve showing crystal filter and part of the bandwidth switching which includes also switches for the audio filter and i.f. gain.

This view of the inside of the receiver shows the gang capacitors, the crystal calibrator in the centre and the aerial matching capacitor on the right.

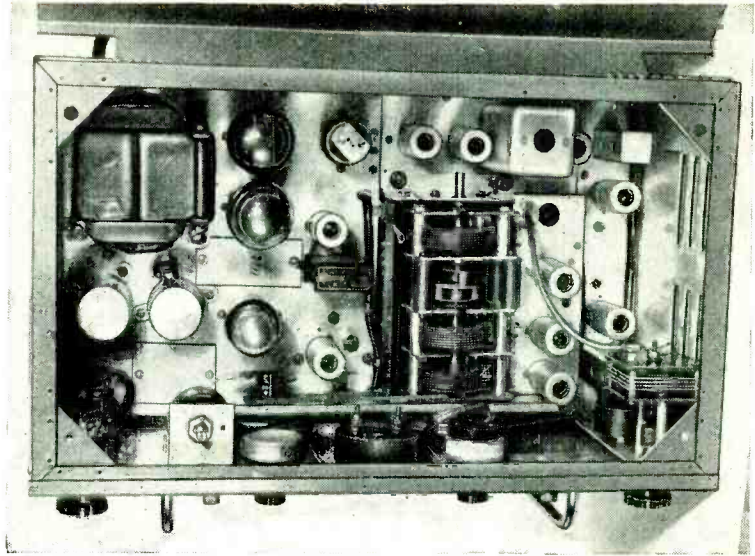

an audio filter, 1.5 kc/s, 0.5 kc/s and 0.5 kc/s plus an audio filter. A quartz crystal gate is used for the last three and the audio filter mentioned, which is used mainly for c.w. reception, has a mid-point frequency of 950 c/s and, with the crystal, gives an effective bandwidth of about 100 c/s.

Although the frequency changer is an EHC35 triode-hexode valve it has a separate oscillator (EF91), but this combination is not uncommon in communications receivers.

It is followed by the three i.f. stages already mentioned, then by an EB91 double diode combining the functions of second detector and a.g.c. with another EB91 for the noise limiter. There is also a beat oscillator (EF91) for c.w. reception, the 500-kc/s crystal calibrator (EF91), a penultimate a.f. amplifier, and finally a pentode output stage giving about 4 watts of audio for an external 3-ohm

loudspeaker. Provision is made for headphones. The crystal calibrator is not exclusively a refinement, but it plays a large part in the bandspread system. Without it there would be some uncertainty in setting the main tuning dial to the exact beginning of the bandspread portion. With it all uncertainty is removed and the frequency calibrations of the bandspread dial then have a real meaning. Opinions may differ regarding the value of an "S" meter, but no communications set appears to be without one. They can be of considerable help if the receiver's gain is kept reasonably constant, not only over the individual ranges but over the waveband as a whole. In the DCR19 a serious effort has been made to achieve this by adjusting the gain of the i.f. amplifiers when switching from one bandwidth to another and in the r.f. amplifier by suitable design of the interstage couplings. From the frequency changer to the second detector the gain of the set is controlled normally by a.g.c. voltages

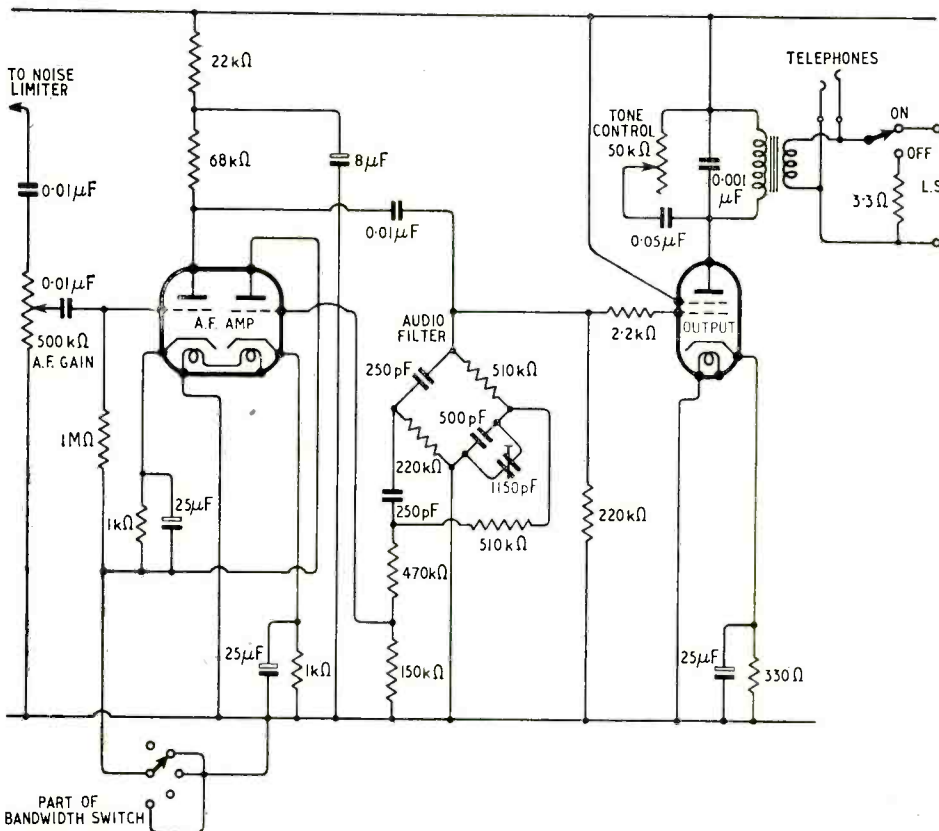

Incorporated in the first audio amplifier is a negative feedback circuit which behaves as an audio filter. The negative feedback becomes operative only when the bandwidth switch brings the audio filter into use. A dummy load is incorporated for use with telephones.

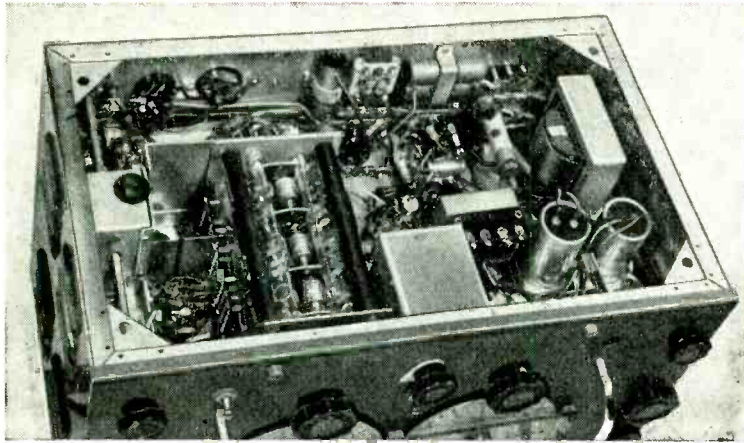

Removing the bottom plate of the cabinet reveals the coil turret, boxed-in b.f.o. (in centre) and gives access to all the under-deck wiring.

developed by the signal. The r.f. stage is not controlled in this way, but there is a manual gain control having a limited effect, as this valve is not one of the variable- μ kind. This control must be set to maximum gain position for the "S" meter readings to have any meaning.

Manual control of the i.f. gain is provided as an alternative to, but not in conjunction with, a.g.c., and this is effected by applying a variable negative bias, derived from a resistor joined between h.t. negative and chassis, to the first two i.f. stages. A potentiometer is connected across this resistor. All stages have cathode resistors for providing minimum bias.

The receiver is a.c. mains operated and incorporates a power transformer, valve rectifier and all smoothing circuits, a VR150/30 voltage stabilizer giving a perfectly steady d.c. voltage for the local oscillator, mixer screen, beat oscillator and for "bucking" the "S" meter.

Though not difficult to operate, this Denco set calls for a few hours of handling fully to appreciate its merits. Sensitivity is high, which is not surprising with three i.f. amplifiers, and it is well maintained throughout the entire waveband. Exceptionally good results were obtained on the highest frequency range in daylight.

The lack of a bandwidth intermediate between 1.5 and 8 kc/s was occasionally felt as the first is rather narrow for telephony while the second is rather broad for some parts of the short-wave ranges, when a 3.5 kc/s bandwidth is generally the most useful. This does not mean to say that speech is by any means unintelligible with a 1.5 kc/s bandwidth; it is not, but the receiver must be very accurately tuned, and this is where the "S" meter comes in very useful. Slight mistuning under these conditions can produce quite noticeable distortion and, with very strong signals, to overloading of the i.f. stages which normally depend solely upon a.g.c. to control the gain. Of course, it is always possible to turn to manual control, but the a.g.c. behaves so well on telephony (and m.c.w.) and c.w. telegraphy that one is reluctant to dispense with its aid.

For c.w. reception the time constant of the a.g.c. system can be lengthened considerably by switching to the "c.w." position, and under these conditions there is no rise in sensitivity (and in background) during the brief intervals between morse characters.

When the proper procedure is followed the band-

spread calibration becomes surprisingly accurate. On the 80-metre amateur (3.5 Mc/s) band it is easily possible to read a station's frequency to within 2 kc/s on the dial, and as the calibration of each of these ranges is checked initially against the 500-kc/s crystal oscillator, a very high order of accuracy is possible. On the 10-metre (28 Mc/s) band the reading accuracy is to within about 5 kc/s.

Checks of the calibration made throughout the waveband, and using the 500-kc/s oscillator, showed that the frequencies marked on the scale are, in the main, to be relied on. In a few cases small discrepancies were noticed but in the majority of cases they amounted to little more than the thickness of the line on the cursor.

Six coloured spots are marked on the cursor for range identification, and they tally with like coloured spots on the waveband change knob which operates the coil turret.

No other indication of range, or position, appears on the turret control so that in a poor light, or if the operator is a little uncertain of his colours (the blue and the green were not very distinct on our receiver), confusion might arise. Figures or letters to supplement the coloured spots would be desirable.

To sum up, the DCR19 possesses about as much sensitivity as can be used in any ordinary location. Some experience is necessary before the best can be extracted from it, but this qualification is not exclusive to radio sets. In the main, the set gives an extremely good account of itself and performs the functions one expects of a communications receiver. Some emphasis has been laid on the qualities for amateur use, and in view of its general form and price it should have a wide appeal in this sphere.

The receiver is housed in a well-ventilated metal cabinet with a hinged lid that folds right back and the finish is grey enamel.

The overall size of the set is $16\frac{1}{2} \times 10\frac{1}{2} \times 11\frac{1}{2}$ in, the weight 30 lb and the price £49. The makers are Denco (Clacton), Ltd., Old Road, Clacton-on-Sea, Essex.

Scaled Valve Containers

A NEW method of packing electronic valves for dispatch overseas has been introduced by the General Electric Company. Cylindrical flanged containers are formed by impact extrusion from an aluminium slug and fitted with lids which are hermetically sealed by the cold pressure welding process recently evolved by the G.E.C. Research Laboratories.

"K.F." Record Changer

We are asked to state that the "K.F." automatic record changer described on page 34 of the January issue is made by Kingsbury Fitch and Company, Sidcup, Kent. Brooks and Bohm are one of the main distributors of this product.

Ionosphere Review: 1949

Sunspot Cycle and Short-wave Propagation Survey, with Forecast for 1950

By T. W. BENNINGTON (Engineering Division, B.B.C.)

ALL doubts as to the time of occurrence of maximum activity in the present sunspot cycle were set at rest with the publication from Zurich, about the middle of 1949, of the final sunspot numbers for 1948. These showed that during no month of 1948 did the mean level of the sunspot number reach so high a value as that which was recorded for May, 1947, and, furthermore, that the twelve-month average value for the sunspot number was also at its peak about that time, namely, at the epoch May/June, 1947. We may therefore assume that that was the epoch of maximum activity in the present cycle.

Since the maximum some rather peculiar variations in sunspot activity have taken place; peculiar, however, only when viewed in relation to the relatively smooth variations which occurred during several years prior to 1947. In short, sunspot activity has not, since the maximum, decreased in anything like a smooth manner, but has undergone some large and erratic up-and-down variations. The activity during 1949 was, on the average, only very slightly lower than that during 1948, a fact which may seem somewhat surprising with the maximum so long past. However, smooth variations—even in the twelve-month running average values—cannot legitimately be expected with confidence, for, if the sunspot cycles of the past 200 years are examined, it is seen that similar up-and-down variations to those which are now taking place are really quite a common occurrence.

Wireless World has, at the end of the past several years, published a review of sunspot and ionospheric conditions, in order to indicate how the conditions for short-wave propagation have varied, and how they may vary in the immediate future. The present review, therefore, will deal with these points as revealed by past measurements of sunspot activity and of ionospheric critical frequency, with particular reference to the changes which occurred during 1949, and to those which may occur during 1950.

Course of the Sunspot Cycle.—In order to show the general course of the present sunspot cycle and the degree of sunspot activity prevailing at present the curve of Fig. 1 is given. In this are plotted the mean annual values of the sunspot relative numbers for a period covering the whole of the last and present sunspot cycles. The maximum in the present cycle is seen to have been considerably higher than that in the last—which was itself a relatively high one—and was, in fact, one of the highest maxima on record since 1749, when continuous records of the sunspot numbers first began. Since 1947—the year of maximum activity—the sunspot activity has decreased only slightly and, during 1949, was very little lower than during the preceding year. Thus the smooth cyclic variations of the preceding years were somewhat upset during 1949. The main point

to note is that the decrease since the maximum has been very slow, so that at the end of 1949 we find ourselves experiencing considerably higher sunspot activity than would have been expected on the basis of the past years' relatively smooth variations.

It will be noted also that, since the sunspot activity is still considerably higher at the end of 1949 than it was at the last sunspot maximum, quasi-maximum conditions still prevail. As will be later shown, ionospheric and short-wave conditions since the maximum have followed the sunspot activity very closely, so that the above remark applies to these as well as to the sunspot numbers. The ionospheric critical frequencies in northern latitudes were, in fact, somewhat higher in the autumn of 1949 than in that of 1948 and only slightly lower than those for the maximum year of 1947. The frequencies usable for short-wave communication are still very high.

Ionospheric Variations.—The top (full line) curve in Fig. 2 gives the monthly mean values of the sunspot relative numbers for each month during the present sunspot cycle, while the two bottom (dashed) curves give the monthly means of the F_2 -layer critical frequencies for noon and midnight respectively. The latter data are those obtained at the Slough station of the D.S.I.R.

Despite erratic month-by-month variations sunspot activity showed a generally increasing tendency from the minimum of 1944 to the maximum in May, 1947. Since that time the variations have often been of greater amplitude, and after decreasing considerably for several months the sunspot number has then several times returned to a value almost as great as that of the maximum. So far as 1949 is concerned it cannot be said that any decided tendency to decrease has become apparent.

The critical frequency curves, which have large seasonal variations in them, both show a gradual

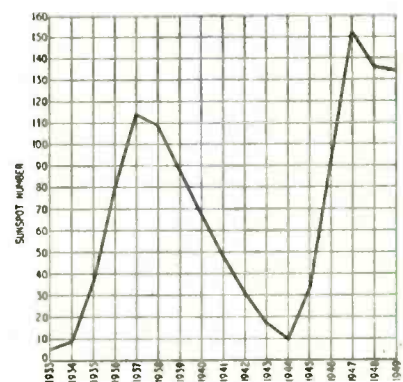

Fig. 1. Mean annual values of sunspot relative numbers.

upward sweep towards the maximum, but since then only a slight tendency to decrease. As has been said the noon value for November, 1949, was greater than that for the same month of the previous year, indicating that higher daytime working frequencies could have been used for short-wave communication. Short-wave working frequencies during this, the third winter season after the maximum, were still of the very high order generally associated with the sunspot maximum itself.

The seasonal variations in the critical frequency curves are very interesting in themselves. So far as the noon values are concerned it is seen that the lowest occur in summer and the highest towards the winter, and that there is a far greater difference between summer and winter values when the sunspot activity is high than when it is low. This means that the magnitude of the critical frequency increase due to the effects of the solar cycle is far greater in winter than in summer.

It is very interesting to note the small subsidiary decrease in critical frequency which occurs in the noon curves at the extreme mid-winter period, resulting in the peak seasonal values occurring at about November and February. It will be observed that this decrease has occurred during every winter of the present cycle, though during the 1947/48 winter alone there was no subsequent recovery after the decrease, resulting in the curve for that winter being a single-peaked one, whereas all the others are double-peaked. It will be noted that during January and February, 1948, there was a sharp decrease in the sunspot number, and there can be little doubt that this lowered solar activity, which occurred at a time when the critical frequency usually increases, was the responsible factor.

Such an occurrence as this well illustrates the difficulties with which forecasters of ionospheric conditions have to contend when making predictions for short-wave propagation some months ahead.

The midnight critical frequency curves show (as is always the case) seasonal variations of a character opposite to those for noon, the highest values occurring in mid-summer and the lowest in mid-winter. It is due to the earlier onset of darkness in winter than in summer, during which ionization by the sun ceases and only recombination takes place.

Correlation between Sunspot and Ionospheric Measurements.—In Fig. 3 are given (full line curve) the twelve-month running average values of the sunspot number during the present cycle, and (dashed line curves) the twelve-month running averages of the noon and midnight F_2 -layer critical frequencies over the same period, taken from the measurements made at Slough. By taking twelve-month running averages of these quantities the month-by-month variations in the sunspot number and the seasonal variations in the critical frequencies are smoothed out, so that the long-period effects in both quantities are made more apparent. The twelve-month average for the epoch at the centre of any month is the average of the twelve monthly means having that month as the centre.

These curves show that both noon and midnight critical frequencies responded to the changing sunspot activity very faithfully, though towards the maximum the sunspot number appeared to increase more rapidly than the critical frequency. Generally speaking, the correlation between the curves—sunspot and critical frequency—is very good, and it may be mentioned that the same good agreement between the sunspot curve and those for critical fre-

Fig. 2. Relationship between solar activity changes and propagation conditions: monthly mean values of sunspot numbers and of noon and midnight F_2 -layer critical frequencies during the present sunspot cycle.

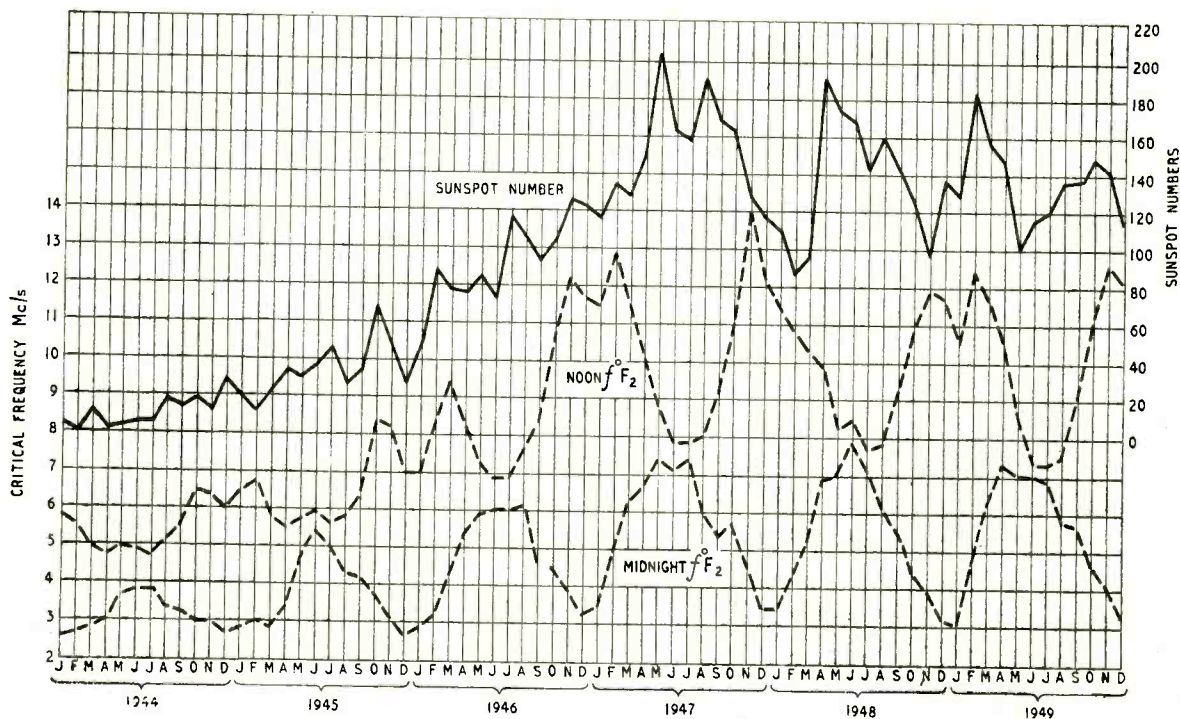

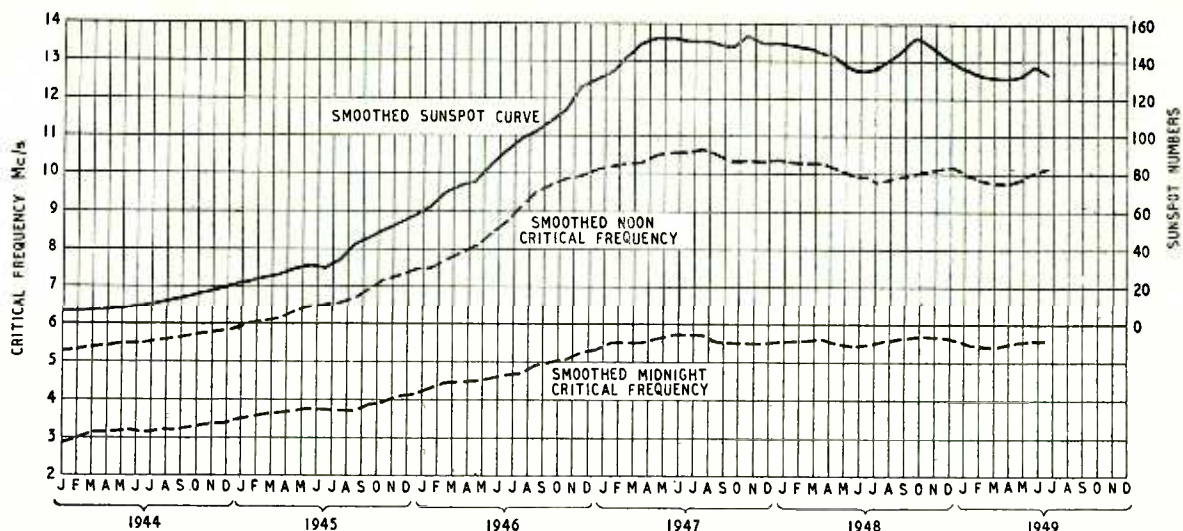

Fig. 3. Twelve-month running averages of sunspot numbers and of noon and midnight F-layer critical frequencies.

quency can be had for other times of day, and for other ionospheric layers, though the magnitude of the variation is different for different times of day, and for different layers. All this shows that the critical frequencies, and thus the m.u.f.s, for short-wave communication, are, at least to a first approximation, directly proportional to the sunspot number.

Having noted that the maximum in the sunspot curve occurred at the epoch May/June, 1947, we become particularly interested in what has happened to both curves since that time, and more particularly during the last 12 months. It will be noted that in a twelve-month running average curve it is only possible to plot up to an epoch six months back from the date of the latest data available. The smoothed sunspot curve—indicating the general degree of solar activity—is seen to have undergone but a slight measure of decline since the maximum, and there has been one very considerable increase to nearly maxima values. Each trough and peak in the sunspot curve is seen to be reflected in those for the noon and midnight critical frequencies, though the latter show these effects somewhat later. For example, the maximum in both critical frequency curves appears to have occurred one month later than that in the sunspot curve, while the trough of May/June, 1948, and the peak of September/October, 1948, are followed by similar troughs and peaks in both critical frequency curves about two months later. All this, when one considers the rather arbitrary nature of the sunspot number, is rather remarkable.

The year 1949 can be regarded as one of particularly good short-wave conditions, for the following reasons. When the ionization of the F₂-layer is exceptionally high, as it was during 1949, the high limiting frequency for short-wave communication is at its greatest value. Under the same conditions of high sunspot activity the ionization of the D-layer—the principal absorbing region—is also raised, but only to a moderate extent as compared with that of the F₂-layer. The absorption determines the low limiting frequency, and as this is not unduly increased, it means that the band of useful frequencies is exceptionally wide. Such wide band conditions

will not prevail when sunspot activity becomes appreciably lower and the restriction of useful bandwidth will become particularly acute at night.

Practical Results.—That the highest frequencies actually propagated during 1949 were of the same order as during 1948 is confirmed by the records of reception conditions in this country during 1949. The critical frequency curves of Fig. 2 imply that, in the ionosphere immediately above Slough the mean m.u.f. for February was of the order of 41 Mc/s, that in June it had fallen to about 24 Mc/s, and in November had risen again to the order of 42 Mc/s, a value slightly greater than that of November, 1948. Of course, the m.u.f. is much modified by conditions over the whole transmission path, which generally tend to reduce it from the value prevailing at either end, on the other hand it frequently is higher than the mean value for a particular month. Nevertheless, these figures give some idea of the order of things to be expected.

The records show that during January, February and March, American police and other signals were frequently received in this country on frequencies of 36 to 42 Mc/s, whilst the London television service on 45 and 41.5 Mc/s was received in South Africa on many occasions. In March there were also one or two reports of amateur reception on 50 Mc/s in this country from South Africa. In late April the amateur frequency of 28 Mc/s began to show signs of failing in certain directions, in May this effect became accentuated, whilst in June and July it was very seldom usable. In April the London television station was received in South Africa frequently, in May on a few occasions only, and in June and July not at all. By September 28 Mc/s was becoming much more frequently usable in many directions from this country, while by October it was in regular use over most circuits. During September television was received in South Africa on seven days, whilst in October such reception again became frequent. In November and December American police and f.m. signals on frequencies up to 43 Mc/s were again received here frequently, and television was almost regularly received in South Africa.

These results exemplify the high order of fre-

quencies the ionosphere is at present capable of propagating, and closely agree with those indicated by the ionospheric measurements.

Forecast for 1950.—It is impossible to say, from a study of the top curve of Fig. 3 how the sunspot activity may vary during 1949. As is seen, the activity of late has shown no very definite trend. All things considered, however, it is likely to decrease and even to do so at a somewhat greater rate than has been apparent since the maximum. If the cycle is compared with the more recent of the past ones this would appear to be the most likely thing to happen, and from this comparison we should estimate that the running average sunspot number for the epoch at the middle of 1950 might be about 106. If this were so it is probable that the running average noon critical frequency will fall to about 9.5 Mc/s, and that for midnight to about 4.8 Mc/s.

We cannot here venture to predict what the m.u.f. for each month of 1950 are likely to be, but if the sunspot variation is of the order indicated above the m.u.f. for longest distance working in these latitudes should, by November, 1950, have fallen to about 36 Mc/s, as compared with 42 Mc/s in November,

1949. The "optimum working frequency" should then be about 30.6 Mc/s. The detailed specification of o.w.f.s. for every direction from this country is, of course, very complicated, and cannot be attempted here.

Predictions for certain circuits will be given month by month in "Short Wave Conditions." So far as the frequencies now generally in use for long-distance communication are concerned it does not appear likely that any great changes will take place in 1950, for not until sunspot activity has decreased considerably do the ionospheric changes begin to make themselves felt and the regularly used frequency bands become unworkable. It is unlikely, however, that the amateur 50-Mc/s band will be workable for long-distance communication at any time during the year, or that the 28-Mc/s band will be usable from about April to October.

Summing up the prospects for 1950, we may use exactly the same words as concluded this review last year, by stating that during 1950 "good radio conditions should in general prevail, and conditions tend to favour the high, but not the exceptionally high, short-wave frequencies."

SHORT-WAVE CONDITIONS

December in Retrospect : Forecast for February

THE average maximum usable frequencies for these latitudes decreased both by day and night during December, which was in accordance with the usual mid-winter trend. Day-time working frequencies were, however, still relatively high, and American police and other transmissions on about 40 Mc/s were often received in this country during the first half of the month. Reception of the London television service in South Africa was not so frequent as during November. The 28-Mc/s band was usable on undisturbed days at the appropriate times over most circuits. Night-time working frequencies above 7 Mc/s were not *regularly* usable.

Sunspot activity was, on the average, considerably lower than during November, and lower, in fact, than in any month since June.

December was an exceptionally quiet month and no severe ionospheric storms occurred. Storms of minor intensity took place on 4th, 7th-8th, 10th-12th, 17th-19th. A severe Dellinger fadeout occurred at 1256 on 12th, but only one other, of minor intensity, was reported during the month.

Long-range tropospheric propagation apparently occurred on several occasions during the month, and was particularly noticeable on the evening of 7th.

Forecast.—During February day-time m.u.f.s. in these latitudes should be considerably higher than during the past two months, whilst night-time m.u.f.s. should also increase.

Long-distance working frequencies should therefore be exceptionally high by day, and frequencies as high as 28 Mc/s should be *regularly* usable over most circuits at the appropriate time of day, whilst those up to about 40 Mc/s may become workable on occasional days during the month. At night, frequencies of the order of 7 or 8 Mc/s are likely to be the highest *regularly* usable over most circuits.

As a rule ionospheric storms are not particularly frequent during February, but those which do occur are often very troublesome during the dark hours.

The curves indicate the highest frequencies likely to be usable over four long-distance circuits from this country during the month.

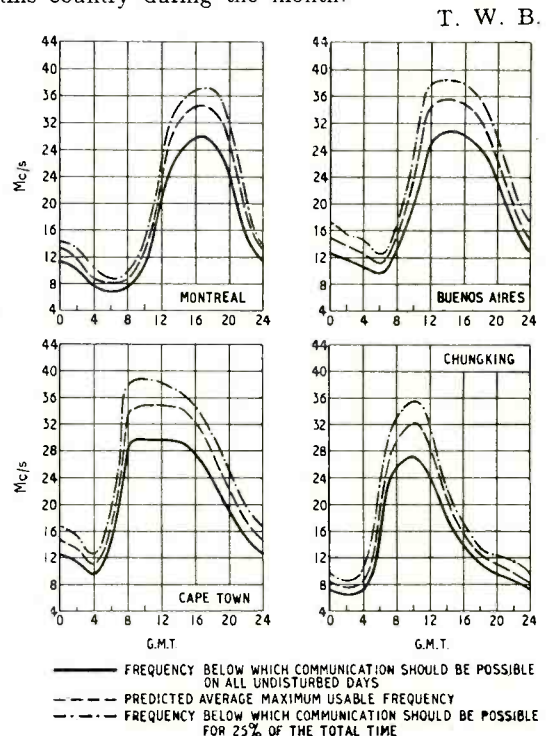

WORLD OF WIRELESS

New International Organization? Television Standards for Europe ♦ "H" Aerial Controversy ♦ Servicemen's Wages

European Broadcasting

WHEN the Copenhagen Convention and wavelength plan for European stations was drawn up it included the provision that "an international expert organization" should be appointed to supervise the introduction of the Plan—due on March 15th.

It will be recalled that for the past two years or more there have been two European broadcasting organizations—the International Broadcasting Union (U.I.R.), which has been operating for many years, and the International Broadcasting Organization (O.I.R.), which was formed in 1946.

Great Britain is not a member of either organization, having withdrawn its support from the U.I.R. some years ago. It is perhaps understandable therefore that the B.B.C. has been asked to convene a conference of the broadcasting organizations of countries in the European zone which are members of the International Telecommunication Union. The object of the conference, which is arranged to open on February 6th, is to form a new European broadcasting organization. As the president of the U.I.R. was present at the meeting in Paris, at which this decision was taken, it is presumed that the U.I.R. will be superseded by the new organization.

This decision follows quickly upon the announcement that eleven member countries have withdrawn their support of the O.I.R. on the grounds of the domination of the Eastern European bloc.

International Television

WITH a view to the cultural unification of television in Great Britain, France, Belgium, the Netherlands and Luxembourg, representatives of each of the countries met in London on January 10th.

It will be recalled that at a recent meeting in Zurich, representatives of France agreed to change her present 455-line transmissions to conform with the British 405-line standard. France further stated that she would continue to develop her 819-line system. It was an-

nounced by the British representatives that when a change was made in this country to a higher definition it would be to 800 lines or more.

The Netherlands has rejected both standards in preference for 625 lines which, when the difference in mains periodicity is taken into account, is comparable with the American 525-line system.

The outcome of the meeting is awaited with interest.

Television Aerials

CONSIDERABLE interest centres around the television aerial—especially the "H" variety—at the present time. Whilst it cannot be claimed that these aspirate excrescences are things of beauty, they are essential in areas of low field strength. It is only in places where the signal is strong that a loft aerial is adequate. It is therefore with some misgivings that we read of the decisions of a number of borough and district councils prohibiting their use.

There have been a tremendous number of references to this matter in the lay Press, especially since the opening of the Midland station. Whilst some councils have banned the erection of television aerials on their property, others require a deposit of as much as £5 from tenants before they are allowed to erect an aerial—part of this is returnable

when the installation has been approved by the borough surveyor.

In one housing estate, only indoor aerials are permitted, except in the case of bungalows where a single dipole is allowed. Many boroughs have stipulated that aerials must be fitted by an approved dealer.

Midland Exhibition

THE Radio Industry Council is planning to hold an exhibition at Castle Bromwich, Birmingham, in September, with television as the main feature. As already announced there will not be a national radio exhibition at Olympia this year.

Service Technicians' Wages

A NEW scale of wages for certified service technicians has been announced by the Joint Standing Committee for the Radio Service Trade. Technicians on the Register of the Joint Standing Committee (previously known as the Radio Service Trade Register), will now receive the following minimum weekly rates according to the class of certificate held (the previous rate was in each case 7s 6d less):—

Holders of certificate "A," which is issued to persons admitted to the register by virtue of their having passed the R.T.E.B. examination, £6 12s 6d per week.

Holders of certificate "B," which is issued to radio service technicians admitted to the register on the basis of having served an approved apprenticeship or having had five years' experience in an approved employment, £6 7s 6d per week.

Holders of the television certificate, which is issued to holders of "A" or "B" who have also satisfactorily finished the television course of a manufacturer, £6 17s 6d a week.

The minimum wage for servicemen over 21 who are not on the Register is £5 5s.

Servicing Certificate Exam

THE Radio Trades Examination Board announces that the closing date for entries for the next Radio Servicing Certificate examina-

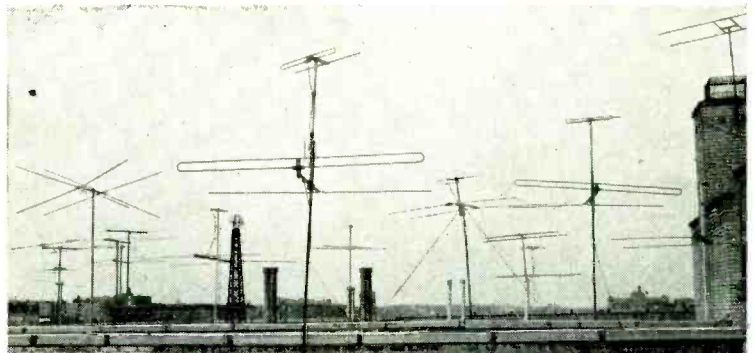

NEW YORK SKY-LINE. This photograph of the variety of television and f.m. aerials on a block of flats in New York is pertinent in view of the television aerial controversy in this country. There are, of course, 7 television stations in New York, all working on different frequencies.

ation, which is held jointly by the R.T.E.B. and the City and Guilds, is February 1st.

The written examination will be held on May 2nd and 4th at centres throughout the country, and the practical examination on May 20th at only five centres—London, Birmingham, Manchester, Glasgow and Bristol.

Further details are obtainable from the R.T.E.B., 9, Bedford Square, London, W.C.1.

B.B.C. Governors

THE KING has approved the appointment of three new Governors of the B.B.C. in place of Sir Richard Peck, Miss Barbara Ward and Geoffrey Lloyd, who retired at the end of the year. The new Governors, who will serve for two years, are Lord Tedder, Lord Clydesmuir and Prof. Barbara Wootton.

The seven members of the Board of Governors control the policy of the B.B.C. and it is to them that the Director-General—Sir William Haley—is directly responsible for the efficient working of the Corporation. The chairman of the Governors is Lord Simon and the other members, the Marchioness of Reading, Dr. Ernest Whitfield and John Adamson.

Standard Frequencies

AN experimental standard frequency transmitting station is being operated by the U.S. National Bureau of Standards on the Island of Maui, Hawaii. This station, which uses the call WVVH and operates on 5, 10 and 15 Mc/s with a power of 3 kW, is being used in addition to WWV, Washington.

The station has been installed to investigate problems relating to the simultaneous operation of more than one transmitter on the frequencies allocated at Atlantic City for standard frequency broadcasts. Details of the station were given in the September issue of our New York contemporary, *Communications*.

HONOURS

John V. Foll, managing director of Muirhead & Co. has been made an Officer of the Order of the British Empire (O.B.E.).

Among the recipients of the M.B.E. are:

Thomas M. Brennan, who is a radio officer of Flight Refuelling, Ltd., for services in the Berlin Airlift;

Henry G. M. Castell who is attached to the Diplomatic Wireless Service in the Foreign Office;

Ernest Hoyle, chief draughtsman at the Ministry of Supply's Telecommunications Research Establishment, Malvern;

Kenneth B. Ling, superintendent of Standard Telephones and Cables' factory at Treforest, Glamorganshire;

James B. Stevenson, a director of E.M.J. Factories, Ltd.; and

Geoffrey W. Warren, a physicist in the G.E.C. Research Laboratories, Wembley.

The British Empire Medal has been awarded to James D. Sweetnam who is assembly superintendent at E. K. Cole's Malmesbury, Wilts, factory.

PERSONALITIES

Air Cmdr. L. Dalton-Morris, C.B.E., has been appointed chief signals officer at the Middle East R.A.F. Headquarters at Ismailia, Egypt. For two years he has been commandant of the R.A.F. Central Signals Establishment at Watton, Norfolk, prior to which he was Director of Signals at the Air Ministry. During the war he was associated with the development of radio and radar counter-measures.

Dr. Harry F. Olson, director of the R.C.A. Acoustical Research Laboratory, Princeton, N.J., has been awarded the first John H. Potts Memorial Medal by the Audio Engineering Society of America "for outstanding accomplishments in the field of audio engineering." The medal is named after the late Editor of our New York contemporary, *Audio Engineering*.

A. John Gale, who was appointed television manager of the Scophony-Baird factory at Wembley a year ago has gone to the United States to investigate the marketing of Baird television receivers in North America.

A. C. Gale has been appointed manager of the Liverpool district office of the Edison Swan Electric Company.

J. S. Mitchell, who for many years was commercial manager at Cossor's, has joined Sobell Industries in an executive capacity.

R. Petch has been appointed by E. K. Cole as Outside Television Service Engineer covering the London area.

C. Clark Ramsay, who has been Press Relations Officer with E. K. Cole for four years, is returning to the publishing world. He is rejoining George Newnes, Ltd.



M. J. PULLING, M.A., who was recently appointed B.B.C. Senior Superintendent Engineer (Television), is vice-president of the British Sound Recording Association.

IN BRIEF

Receiving Licences.—Although there were 17,350 fewer broadcast receiving licences in force at the end of November than a month earlier, 18,350 new television licences were issued during the month. The total number of licences at the end of November was 12,106,900, including 206,700 for television. A notice bearing the words "Warning! Is Your Wireless Set Licensed?" is being posted in all Post Offices reminding owners of broadcast and television sets of the necessity of obtaining a licence.

Radio Control.—The First International Radio-Controlled Model Boats Contest to be held in this country, has been arranged for Easter Sunday and Monday, April 9th and 10th. Details of the contest, which will be held at Fleetwood, Lancs, are obtainable from J. Heathcote, General Secretary, Radio-Controlled Models Society, 8 Henniker Street, Swinton, nr. Manchester. The society is exhibiting at the second Northern Models Exhibition which is being held in Manchester from March 24th to 26th.

Standard Solder.—A revision of the war emergency edition of the British Standard BS219, which restricted the number of grades of solder to five, has now been issued. It includes the composition of five antimonial and five non-antimonial solders. Appendices give the melting characteristics and typical uses of the solders listed and information on solders intended for use at temperatures higher than those for which normal alloys covered by the Standard are suitable. BS219:1949 is obtainable from the British Standards Institution, 24 Victoria Street, London, S.W.1, price 2s post free.

Ship-to-Shore Stations.—The British Post Office short-range ship-to-shore coastal radio stations at Malin Head, Donegal, and Valentia, Co. Kerry, which since the establishment of the Irish Free State have been operated by the Irish Post Office on behalf of the British Post Office, have now been transferred to the Irish Government.

S.B.A.—Television Interference.—Owing to the interference caused by the Alexandra Palace television transmitter with the reception of S.B.A. (Standard Beam Approach) in aircraft flying in the London area, one of the marker beacons (Type R1125D) has to be modified. The selectivity of the receiver has been found insufficient when a horizontal wire aerial, capacitively coupled to the grid circuit of the first valve, is used. Details of the modifications are given in the Ministry of Civil Aviation's circular 141/1949.

G.R.S.E.—At the fifth annual general meeting of the Guild of Radio Service Engineers, the following officers were elected;— president, M. Majury; chairman, T. F. Winning; vice-chairman, W. T. G. Wanden. The recently appointed assistant secretary is J. A. Monk and the registered office of the Guild is now 88 Madeira Road, Holland-on-Sea, Essex. (Tel.: Holland-on-Sea 3101.)

Television Explained.—Some 750 teen-agers attended the I.E.E. Christmas Lecture for Older School Children on "Television," delivered by H. L. Kirke, head of the B.B.C. Research Department, on January 3rd and 4th.

The lecture, which was illustrated by lantern slides, included mechanical and electronic demonstrations of the principle of scanning.

French Scientific Instruments.—A number of research organizations in France have combined to present in this country an exhibition of French scientific instruments—including some for radio research. The exhibition, during which a number of lectures will be given, is to be held at the Science Museum, South Kensington, London, S.W.7, from February 9th to 26th.

New Transmitter.—The B.B.C. has recently brought into service a new 2-kW transmitter in Bellahouston Park, Glasgow, to radiate the Third Programme. It replaces the 1-kW transmitter installed in Broadcasting House, Glasgow, as an emergency measure in 1940.

C. & G. Report.—The recently issued report of the Department of Technology of the City and Guilds of London Institute for 1948 shows that there was a net increase in the number of entries for the subjects grouped under "Telecommunication Engineering" of 2,208. Of the 20,962 examinees, 8,034 failed. Some 28 per cent of the 213 who sat for the Radio Service Work Examination failed to qualify.

B.S.R.A. Exhibition.—Plans are being made by the British Sound Recording Association to hold an exhibition of sound recording, reproducing and allied equipment for the weekend of May 20th and 21st, 1950, at the Waldorf Hotel, London, W.C.2. Lectures and demonstrations will be included in the programme.

Imports.—Among the range of goods from which import licensing restrictions were removed on January 5th are "parts of gramophones and radio-gramophones." Certain countries, mainly those in the "dollar area" and Eastern Europe, are excluded from this relaxation.

Channel Islands Telephony.—The temporary single-channel radio-telephone link between Alderney and Guernsey has been replaced by a permanent six-channel link.

Elementary Radio Classes, including Morse instruction, are being held on Wednesdays and Thursdays at 7.45 at the Deptford Men's Institute, Childeric Road School, New Cross, London, S.E.14.

World Broadcasting.—The 1949 edition of the "World-Radio Handbook for Listeners," published in English by O. Lund Johansen, Copenhagen, Denmark, is now available from Surridge Dawson and Co., 101 Southwark Street, London, S.E.1, price 6s 6d. It gives a wealth of information on the world's broadcasting stations and the organizations operating them.

Amateur Radio.—"The Transmitting Licence—or how to become a radio amateur," published by the Incorporated Radio Society of Great Britain, New Ruskin House, Little Russell Street, London, W.C.1, is now available in its third edition. Its purpose is well explained in the following opening passage taken from the introduction—"... to present in a convenient form the essential information required by those who wish to obtain an Amateur Transmitting Licence." The price is 9d (1s by post).

Philips sound reproducing equipment being installed in Exeter Cathedral includes twelve microphones and 32 loudspeakers. The speakers will be incorporated in the lighting pendants.

Industrial R.F. Heating.—A special course of four lectures on "High-Frequency Heating in Industry" has been arranged by the Polytechnic, Regent Street, London, W.1. The lecturers are J. A. L. Wharton, R. E. Bazin, P. M. Paine, and E. S. Wilson, who are members of the research and design staff of Redifon, Ltd. Enrolment forms for the course, which will be given on Fridays at 6.30 commencing on February 24th, are obtainable from the Head of the Electrical Engineering Department. The fee for the course is 10s.

Student Exchange.—The second annual report of the International Association for the Exchange of Students for Technical Experience (I.A.E.S.T.E.), which was founded in 1948, shows that the number of students taking advantage of industrial experience overseas increased from 920 to 1,236. Great Britain sent 285 overseas and received 314. The next highest among the ten countries participating was Sweden. Ten radio manufacturers in this country received foreign students.

Professional Engineers.—Two additional branches of the Engineers' Guild—an association of professional electrical, mechanical and civil engineers—have recently been formed—the North-Western and the Southern.

Courses in Radiotechnology have been started at Allan Glen's School, Glasgow, as part of the Glasgow Corporation's Further Education Scheme.

A Joint Conference is being organized by the Institutions of Electrical, Mechanical and Civil Engineers to be held in London to coincide with the Festival of Britain, 1951. The proposed dates are June 4th to 15th.

Television Costs.—It was recently stated by the Postmaster-General that the annual rent of the London-to-Birmingham television link, whether the cable or the radio link was used, would be of the order of £50,000. This will, of course, have to be paid by the B.B.C. to the Post Office.

Scientific Film Census is being undertaken by the Scientific Film Association to bring up to date its records of documentary, instructional, educational and scientific films. Further particulars of the details required are obtainable from the association, 4, Great Russell Street, London, W.C.1.

Servicemen are not covered by the Government Order which specifies statutory wages for retail shop assistants. The Order (No. 2276/49), which came into force on January 23rd, includes, however, shop assistants in the radio and television retail trade.

Apprenticeships.—A brochure has been issued by the English Electric Co. outlining the apprenticeships available in the English Electric group of companies, which includes Marconi's and Marconi Instruments. It is available from the company's head office, Queen's House, Kingsway, London, W.C.2.

Marconi marine radio and radar gear has been installed in the New Zealand Shipping Co.'s latest vessel, *Rangitane*. The first *Rangitane*, which was sunk

during the war, was equipped by Marconi's in 1929.

Ideal Home Exhibition, organized annually by the *Daily Mail*, will be held at Olympia, London, from March 7th to April 1st.

E.M.I. Institutes have acquired new premises at 10 Pembroke Square, London, W.2, for the college. (Tel.: Bayswater 5131/2).

Mullard Equipment, Ltd., is the new name given to the Mullard subsidiary which was previously known as Electronic Transmission Equipment, Ltd. The subsidiary was formed in 1947 for the development and manufacture of communications apparatus. The company's products are marketed by the Communications Division of Mullard Electronic Products, Ltd.

Electronic Tubes, Ltd.—It was announced at the annual general meeting of E.M.I. that all the ordinary shares in Electronic Tubes, Ltd., had been purchased by E.M.I. It will be recalled that Electronic Tubes, manufacturers of c.r.t.s and valves with a factory at High Wycombe, Bucks, were, until recently, a subsidiary of Cossor's.

F. C. Robinson & Partners, Ltd., of Dalton House, Hargate Drive, Hale, Cheshire, have been appointed sole northern agents for Baldwin Instruments and Mullard Electronic Products.

FROM ABROAD

Switzerland.—We have received a copy of the 18th annual report (1948) of the Swiss broadcasting organization. The sections dealing with each of the three main transmitters are printed in the language radiated—Sottens in French, Monte Ceneri in Italian, and Beromünster in German. The material regarding the general organization of Swiss broadcasting—both internal and international—is in French. The statistics show that 84 per cent of the families in Switzerland own broadcast receivers. The total number of licensed sets at the end of 1948 was 969,606.

Anglo-American Exchange of radio engineers is suggested by our New York contemporary, *Tele-Tech*. "The stimulus of an interchange of engineering thought in the field of radio and television should benefit both countries. For the British; U.S. methods of production would be an eye-opener... and some U.S. manufacturers could learn from the solid built-to-last construction of their British counterparts."

A pictorial list of the tuning signals of 77 American television stations is included in the January issue of our New York contemporary *Radio-Electronics*. It is interesting to see that about 50% are purely pictorial and are in no way intended as test patterns to facilitate receiver adjustment.

Indian Licences.—A 50 per cent increase in the broadcast receiving licence fees has been introduced in India. The new licence fee for domestic valve sets is Rs15 and that for sets in business premises Rs50. The fee for community receivers is Rs10 whilst a fee of Rs3 is payable by schools and institutions. The latter fee is also charged for crystal sets.

Indian Peoples' Set.—The design of a cheap medium-wave receiver for local reception is being undertaken by the

Research Division of All India Radio. The prototype two-valve a.c./d.c. set, which is expected to sell at between Rs25 and Rs30, has a cabinet said to cost only 4 annas. The valves used are the 6SJ7 and the 3ZL7GT.

Colour Television Tests.—It is understood from Washington that as a result of the recent investigation to formulate plans for the re-allocation of television frequencies in the U.S., the F.C.C. has called for public tests of colour television. Manufacturers of colour television equipment have been asked to transmit regular daily programmes for a specified period and to provide domestic receivers for the tests.

819-line Television.—The power of the French high-definition television transmitter, which has been in use experimentally since November 15th with a power of only 0.7kW, has now been increased to 3kW. The aerial is erected on the Eiffel Tower, Paris.

International Television.—The Swiss Television Committee has issued a statement following a recent meeting in which it is pointed out that 625 lines is becoming a world standard. The optimum bandwidth for this standard has yet to be agreed internationally. The two possibilities are 4.25 and 5Mc/s.

NEW ADDRESSES

British Relay Wireless, Ltd.—The head office of B.R.W. and its associated companies, is now at Giltspur House, 6 Giltspur Street, London, E.C.1. (Tel.: City 3280.)

E.M.I. Sales & Service is opening a Midland television service depot at City Chambers, 111-117 John Bright Street, Birmingham.

Mullard has opened a valve and cathode-ray service depot at 108, Dale End, Birmingham, 4. The service is restricted to callers.

Telephone number of the London office and showrooms of E. K. Cole at 5 Vigo Street, W.1., is now Regent 7030/9.

MEETINGS

Institution of Electrical Engineers

Radio Section.—"Ground-Wave Propagation Over an Inhomogeneous Smooth Earth," by G. Millington, M.A., B.Sc., and G. A. Isted, on February 15th.

Informal Meeting.—Discussion on "Interference Suppression," opened by E. M. Lee, B.Sc., on February 13th.

Both meetings will be held at 5.30 at the I.E.E., Savoy Place, London, W.C.2.

Cambridge Radio Group.—"Some Considerations in the Design of Negative-Feedback Amplifiers," by W. T. Duerdoth, B.Sc. (Eng.), at 8.15 on February 7th at the Cavendish Laboratory (Joint meeting with the Cambridge University Wireless Society).

North-Eastern Radio Group.—Discussion on "Control and Measuring Equipment; Electronic versus Non-electronic Apparatus" on February 6th. "Theory and Design of Magnetic Amplifiers," by H. M. Gale, B.Sc. (Eng.) and P. D. Atkinson, M.A., on February 20th.

Both N.E. Radio Group meetings will be held at 6.15 at King's College, Newcastle-on-Tyne.

North-Western Radio Group.—"Printed Circuits, including Miniature Components and Sub-miniature Valves," by J. E. Rhys-Jones, M.B.E., and G. W. A. Dummer, M.B.E., at 6.30 on February 22nd, at the Engineers' Club, Albert Square, Manchester.

South Midland Centre.—"Television Radio Relay Links," by A. H. Mumford, O.B.E., B.Sc. (Eng.), and C. F. Booth, O.B.E., at 6.0 on February 6th, at the James Watt Memorial Institute, Great Charles Street, Birmingham. (Joint meeting with the Institution of Post Office Electrical Engineers.)

Western Centre.—"Magnetic Amplifiers," by A. G. Milnes, M.Sc. (Eng.), at 6.0 on February 6th, at Electricity House, Colston Avenue, Bristol.

Faraday lecture on "Radar," by R. A. Smith, M.A., Ph.D., at 6.30 on February 13th, at the Guildhall, Swansea.

London Students' Section.—"Blind Landing," by T. E. Schilizzi, B.A., on February 1st.

Address by the President, Prof. E. B. Moullin, M.A., Sc.D., on February 20th.

Both Student meetings will be held at 7.0 at the I.E.E., Savoy Place, London, W.C.2.

British Institution of Radio Engineers

London Section.—"Travelling-Wave Tubes," by R. L. Kompfner, at 6.30 on February 23rd, at the London School of Hygiene and Tropical Medicine, Keppel Street, W.C.1.

West Midlands Section.—"Electronics and the Brain," by H. W. Shipton at 7.0 on February 22nd, at the Wolverhampton and Staffordshire Technical College, Wulfruna Street, Wolverhampton.

Scottish Section.—"The Performance and Stability of Permanent Magnets," by A. J. Tyrrell, at 6.45 on February 2nd, at the Institution of Engineers and Shipbuilders, Glasgow.

Mercyside Section.—"The Measurement of Small Currents," by D. R. Hardy, M.Sc. (Eng.), at 7.0 on February 1st, at the Accountants' Hall, Derby Square, Liverpool.

North-Eastern Section.—"Single-Sideband Systems Applied to Long-Range Wireless," by Major S. R. Rickman, at 6.0 on February 15th, at Neville Hall, Westgate Road, Newcastle-on-Tyne.

Television Society

London Meeting.—Demonstration and discussion on television aids—polaroid lenses, filters, aerials and interference suppressors at 7.0 on February 24th, at the Cinema Exhibitors' Association, 164 Shaftesbury Avenue, London, W.C.2.

Constructors' Group.—"Mullard Projection Receiver," by Emlyn Jones (Mullard), at 7.0 on February 9th, at the C.E.A., 164 Shaftesbury Avenue, London, W.C.2.

Midlands Centre.—"The V.H.F. Link," by A. H. Mumford (Post Office, Radio Branch), at 7.0 on February 6th, in the Lecture Hall, The Crown Restaurant, Corporation Street, Birmingham.

Bristol and S.W. Centre.—"The Electronic Engineering Televisor," by W. I. Flack, at 7.30 on February 7th, at the Royal Hotel, Bristol.

British Sound Recording Association

"High Quality Reproduction—How to Achieve It," by H. J. Leak, at 7.0 on February 24th, at the Royal Society of Arts, John Adam Street, London, W.C.2.

Radio Society of Great Britain

"Panoramic Reception," by B. H. Briggs, M.A. (G2FJD), at 6.30 on February 24th, at the I.E.E., Savoy Place, London, W.C.2.

Institute of Navigation

A symposium of papers on air traffic control at 4.0 on February 17th, at the Royal Geographical Society, 1, Kensington Gore, London, S.W.1.

Guild of Radio Service Engineers

Edinburgh Branch.—"Valves and the Service Engineer," by D. N. S. Toms (Standard Telephones & Cables), at 7.30 on January 26th.

Lecture by F. Henderson of the Osram Valve Department at 7.30 on February 23rd.

Both meetings will be held at Unity House, 4 Hillside Crescent, Edinburgh.

"A.C./D.C.-Battery Power Supplies"

An Important Correction

IN Fig. 1 of the article on page 31 of the January issue it is regretted that incorrect values were given for some resistors in the l.t. and mains voltage adjustment circuits. The corrected circuit is reproduced herewith.

It should also be emphasized that the method of "losing" surplus mains voltage, involving the omission of the rectifier reservoir capacitor, applies only to a.c. mains and this particular circuit should not be used on a d.c. supply.

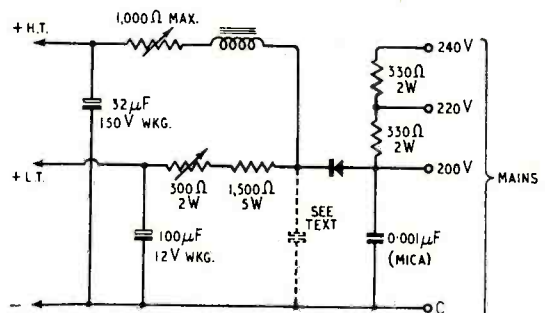

FILTERS

By "CATHODE RAY"

2. Debunking the Cosh—and Other Mathematical Weapons

FOR the sake of those who haven't read Part 1 (and perhaps of some who did) I will start by recapitulating. We found that unless the calculation of filters is to be unbearably tedious or mathematically advanced it is necessary for the load impedance to be related to the impedances of the filter components in a special way. The main result of this relationship is that the impedance measured at the input of every section of the filter is the same, and equal to the load impedance. This particular value of impedance is called the characteristic or iterative impedance and denoted by Z_0 . Directly the form of the filter (T, π , etc.) has been settled, one can write down an equation connecting Z_0 with the impedances of its "arms." For a T section, for example, it is

$$Z_0 = \sqrt{Z_1 Z_2} \sqrt{1 + \frac{Z_1}{4Z_2}} \dots \dots \dots (1)$$

where Z_1 and Z_2 are respectively the total series and shunt impedances of the filter section. In a simple low-pass section, as shown in Fig. 1, $Z_1 = j\omega L$ and $Z_2 = 1/j\omega C$, and when these are substituted in (1) we get

$$Z_0 = \sqrt{\frac{L}{C}} \sqrt{1 - \frac{\omega^2 LC}{4}} \dots \dots \dots (2)$$

We noted that the first factor, $\sqrt{L/C}$, is a constant depending on the filter components, and is multiplied by a second factor which depends on frequency (since $\omega = 2\pi f$). If the frequency is zero, Z_0 is just $\sqrt{L/C}$, a resistance. As the frequency rises, this resistance drops to zero at a certain critical frequency $1/\pi\sqrt{LC}$ (because it makes $\omega^2 LC/4 = 1$). Above that it is a pure inductive reactance, increasing steadily. All this can best be seen by drawing the graph, Fig. 2.

We had taken note of the awkward fact that no practical load behaves in exactly this way, and what most people do is just to use a resistance of $\sqrt{L/C}$ ohms, which is correct at very low frequencies but causes a mismatch at other frequencies. (Usually of course, the procedure is vice versa; you are given a load of, say, 1000 ohms, and you choose filter components such that $\sqrt{L/C} = 1000$.) The results of a mismatch remained to be revealed, and so did the all-important question of how the attenuation of a filter varies with frequency.

Non-Mathematicians Read on!

It is at this crucial stage in the argument that the less mathematically advanced students tantalizingly lose consciousness as a result of a well-aimed blow with a cosh; in other words, the writer resorts to hyperbolic functions. As I said before, coshes and other hyperbolic functions are no more difficult to look up in tables than sines and coses, but the reason for bringing them in at all is not always transparently

clear. It is possible to dodge this issue a little longer, however, and at the same time see something of the answer.

Considering first of all the part of the curve in Fig. 2 up to where the frequency is $1/\pi\sqrt{LC}$, we see that Z_0 is a pure resistance. Therefore all the power put into the filter must be dissipated somewhere. The filter itself has no resistance, so the only place where the power can be dissipated is the load, which (being equal to Z_0) is of course a resistance. If all the power goes right through the filter without loss, there can be no attenuation. So up to a certain frequency—which, you may note, you can make what you like by a suitable choice of component values, because it is $1/\pi\sqrt{LC}$ —the filter doesn't attenuate at all. That is one remarkable fact that can be arrived at simply from the most elementary principles. (But remember the load resistance has to vary with frequency according to the curve in Fig. 2.)

You can see at once from Fig. 1 that there should be no attenuation at zero frequency; the impedance of the series arms is nil and the shunt arm infinity. It is not nearly so easy to see why it should be so at other frequencies. A.c. flowing through the coils is bound to cause a voltage drop, and, with the load resistance falling, the current will tend to increase and cause the drop to be greater. So how can the insertion of the filter have no effect? The explanation is that this increasing voltage drop across Z_1 is exactly

Fig. 1. The type of filter section being considered—a low-pass T—terminated by its characteristic impedance Z_0 (see Fig. 2).

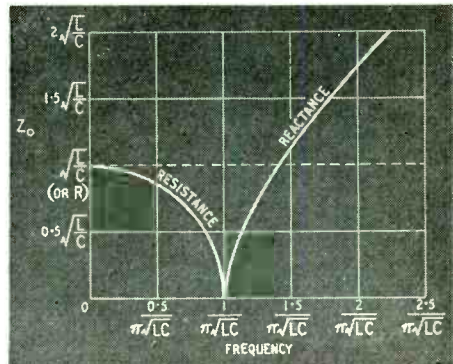
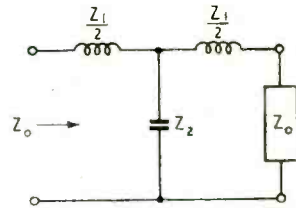

Fig. 2. How the characteristic impedance of the Fig. 1 type of section varies with frequency.

offset by a tendency to resonate with Z_2 . As you know, in a resonant circuit the voltages across the reactances can each be much larger than the input voltage. And the effect of the load resistance is to keep the input current exactly in phase with the voltage at all pass frequencies. It is a fascinating thing to ponder over.

Next, what is the significance of the critical frequency where Z_0 drops to zero (or soars to infinity in the π type)? Its formula, $1/\pi\sqrt{LC}$ will almost certainly have rung a bell by now—or perhaps half rung it? It is so very like $1/2\pi\sqrt{LC}$, the formula for the frequency at which a series circuit made up of L and C resonates. The coincidence is too remarkable to mean nothing; but why should the 2 be missing? In other words, why should the filter's critical frequency be double the resonant frequency?

Looking at Fig. 1 and drawing in the load and generator resistances, which at this frequency must both be zero, we find that the two series arms, each made up of $L/2$ come in parallel with one another and with C. The total inductance in parallel with C is therefore $L/4$, and if you substitute $L/4$ for L in the resonance formula you find the resonant frequency comes out as $1/\pi\sqrt{LC}$. So this mysterious critical frequency is where the filter resonates!

The same conclusion can be arrived at by considering a π section, Fig. 3. At the critical frequency its Z_0 rises to infinity, so it can be regarded as being open-circuited, just as shown. The two capacitance arms are in series with one another, and as their separate capacitances are $C/2$ (to make $2Z_2$) the capacitance in parallel with the coil is $C/4$ and the resonant frequency $1/\pi\sqrt{LC}$, as before.

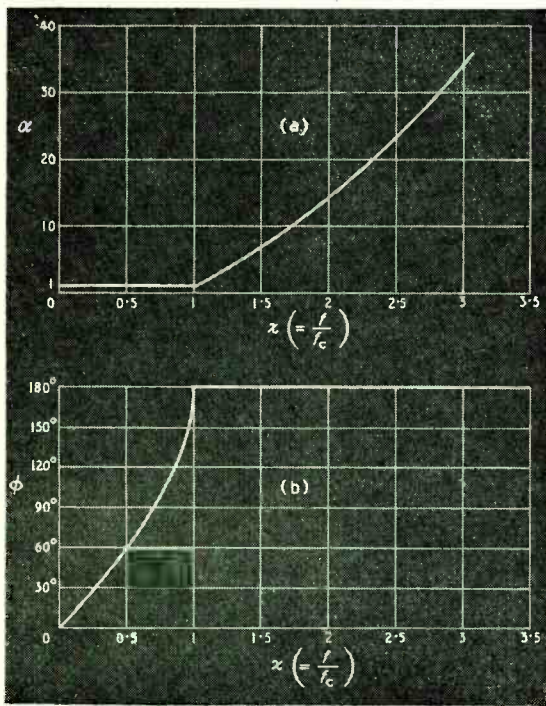
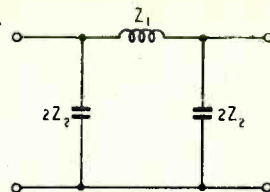

Fig. 4. Attenuation (a) and phase angle (b) curves against frequency for a low-pass ladder filter terminated by Z_0 . Note the abrupt changes at the cut-off frequency (where $f/f_c = 1$).

Fig. 3. Low-pass π section.



At all higher frequencies, the filter (and its load) looks to the generator like a pure reactance, which means that no power is accepted. From a power point of view, therefore, it attenuates completely. That does not mean, of course, that no current or voltage can reach the output. And, let us remember, it is based on the rather unpractical assumption that the load suddenly becomes a reactance, whereas in practice it is likely to remain a resistance. Still, if you consider the situation carefully, you may reach the conclusion that above the critical frequency the filter attenuates. Whether you do or not (and don't be worried if it isn't obvious!) it does in fact; so what we have been calling the critical frequency is known as the cut-off frequency, usually denoted by f_c (sometimes f_0).

Algebraical Detour

And now we can really no longer evade what in days gone by would have been called (not very politely) a *pons asinorum*. This is where, as I said, most writers make good their escape by resorting to the cosh. Actually the thing can be done by perfectly straightforward algebra, greatly aided by j (which we saw in the Feb. 1948 issue was not really a difficult trick to acquire). Most things in so-called higher mathematics can be done by straightforward algebra, but they are apt to be so intolerably tedious that way that they never would be done unless neater and shorter methods had been devised. Unfortunately these short cuts look so dangerous to those who have never gone by them before that they prefer to toil around the long but more familiar routes.

I haven't sufficient space to show in full every step of the way in finding the attenuation of a filter, say as in Fig. 1, but here is a sketch plan:

What you want—the attenuation—can be expressed as the ratio of the input and output currents. The input current (I_i) divides between Z_2 and the second $Z_1/2$ (and Z_0) in Fig. 1. The latter part is the output current (I_0). So what goes through Z_2 must be $I_i - I_0$. Now because $Z_1/2 + Z_0$ and Z_2 are in parallel with one another, the voltages across them are obviously the same. The voltage across Z_2 is $Z_2(I_i - I_0)$ and the voltage across $Z_1/2 + Z_0$ is $I_0(Z_1/2 + Z_0)$. As these two are equal, you have a simple equation connecting I_i , I_0 , Z_1 , Z_2 and Z_0 . Z_0 can be expressed in terms of Z_1 and Z_2 (equations (1) or (2)), and the result can be put into a form showing the attenuation (I_i/I_0 or α) in terms of Z_1 and Z_2 . So when you have chosen Z_1 and Z_2 you can find the attenuation. Because Z_1 and Z_2 depend on frequency you can turn the equation into one connecting α with f , and draw a graph of it. And since the section is terminated by Z_0 , you can use any number of sections and each will have the same attenuation. For two sections the whole attenuation will be α^2 ; for three, α^3 ; and so on. The only tricky part of this algebra is keeping account of the phase. It could be done without j , but j makes it very much easier. A further simplification is to

generalize the whole thing by putting it in terms of f/f_c instead of f . It makes it neater to denote f/f_c by some single letter, say x . Then $\omega\sqrt{LC}/2$ can be written simply as x . Another dodge is to denote $\sqrt{L/C}$, the zero-frequency Z_0 , as R . Then $Z_{1/2} = j\omega L/2 = jRx$, and $Z_2 = 1/j\omega C = R/j2x$.

The final result of all this manipulation should come out as

$$\alpha = 1 - 2x^2 + j2x\sqrt{1-x^2} \quad \dots \quad (3)$$

If you dislike j , the alternative is

$$\alpha = \sqrt{(1-2x^2)^2 + (2x\sqrt{1-x^2})^2} \quad \dots \quad (4)$$

It looks reasonably simple to substitute various numbers for x and draw up a table connecting x and α , from which to draw a graph of attenuation against frequency (relative to cut-off frequency as 1), but there are one or two things.

Starting off with values of x less than 1 (i.e. in what we have reason to believe is the no-attenuation or pass region in a low-pass filter), α calculated by (4) turns out to equal 1 every time. (Remember, (4) gives the magnitude only without regard for phase.) That means that $I_0 = I_i$; so there is no attenuation (Fig. 4(a)).

It is interesting to calculate the phase angle. $1 - 2x^2$ is the in-phase component, and $2x\sqrt{1-x^2}$ the 90° component, so $2x\sqrt{1-x^2}/(1-2x^2)$ is the tangent of the phase angle. Having calculated this, we can find the angle from a table of tangents. The result of this investigation shows that the output current starts off in phase at zero-frequency ($x=0$), and increases steadily to 180° at the cut-off frequency ($x=1$), as in Fig. 4(b). (Incidentally, the shape of this part of the curve is a quarter of a sine wave stood up on end.)

So in the pass region the filter doesn't attenuate but it does shift the phase.

Directly we start putting x = more than 1 in (3) or (4) we encounter the square root of a negative quantity. This brings the j -less users of (4) to a complete standstill, but the j men carry on merrily with (3) by substituting $-2x\sqrt{x^2-1}$ for $j2x\sqrt{1-x^2}$; and the whole equation now appears as

$$\alpha = -(2x^2 - 1 + 2x\sqrt{x^2-1}) \quad \dots \quad (3a)$$

The minus sign signifies what we already know for $x=1$, namely, that the output current is 180° out of phase with the input. And as j is absent for all values of $x > 1$ we see that the phase remains constant at this, as shown by the flat top in Fig. 4(b). The magnitude of α can be calculated straightforwardly now, and rises in a curve as shown in Fig. 4(a).

So now we have full details of the performance of one or any number of low-pass filter sections terminated by Z_0 ; and can easily adapt the method to apply to high-pass filters, and (a little less easily) to band filters. And all without a trace of a cosh or a e^{ix} or any such-like fearsome apparition! Are these things merely to frighten possible intruders away from the filter experts' "closed shop"?

The answer lies in the amount of time and effort you have expended in working out the data for Fig. 4 from equation (3) and (3a)—supposing you have been painstaking enough to have done it. The hyperbolic man just takes a good look at the equation and says "Catch me doing all that work! Why; can't you see? $\cosh \log_e \alpha = 2x^2 - 1$!" And so he looks up his table of coshes, and then finds α from his log_e table or, if he is that sort of man, he will probably not

Fig. 5. Attenuation curves for a filter terminated (a) correctly by the theoretical Z_0 —this is the same as Fig. 4(a) but to a decibel scale this time—and (b) by the practical load resistance $R (= \sqrt{L/C})$.

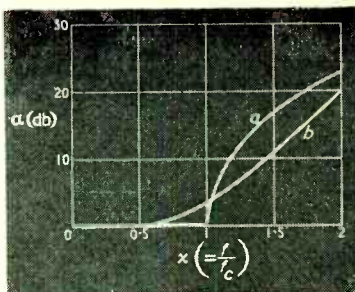

bother, but just call the $\log_e \alpha$ figures the attenuation in "nepers"—units each equal to 8.686 decibels).

The practical value of the cosh, then, lies in the fact that it enables one to dodge most of the work by looking up tables. For instance, when $x=2$, $2x^2 - 1 = 7$, and the thing that 7 is the cosh of is (from the table) 2.632. Multiplying this by 8.686 gives the attenuation in decibels—22.8, which is 13.9 in α ratio. Anybody can do that without knowing anything about the theory of hyperbolic functions.

If 22.8 db at twice the cut-off frequency is not enough, then just add more sections. Two will give 45.6; three, 68.4, and so on. To design a filter to given requirements one would know f_c , the desired cut-off frequency, and also R , the nominal characteristic impedance (at zero-frequency in a low-pass filter). The information we already have gives $L = R/\pi f_c$ and $C = 1/\pi R f_c$ —the component values.

Conditions Near Cut-off

All this is most interesting, but unfortunately it relates to a load impedance that exists only in imagination. It would be much more practical to know what happens when the load is not the fantastically varying Z_0 but the solid constant R . Fig. 2 shows that everything would go according to plan at zero frequency (much use that is!) and probably nearly so at all frequencies much lower than f_c . But near f_c there is bound to be violent mismatching, and in any case all our beautiful calculations based on Z_0 fall down.

That is not to say that they have been a waste of time. As I suggested earlier, the policy is to use this comparatively simple but purely theoretical case as a main framework, and then find out how it is modified by practical conditions such as a constant resistive load and losses in the filter components. Fortunately, the modifications are much less drastic than one might expect. The losses in well-designed filters usually cause a little rounding off near f_c and some reduction in α at the highly-attenuated frequencies. Fig. 5 shows what happens near f_c when $R (= \sqrt{L/C})$ is substituted for Z_0 as the load following a single section. For comparison the Z_0 curve from Fig. 4(a) is repeated, but both curves in Fig. 5 are plotted to a decibel scale. If the load impedance is very different from R —especially if it is much greater—the departures from the Z_0 curve really are drastic; but it is generally not difficult to use R .

When several sections are used the curve becomes rather more complicated, with a noticeable waviness; but it never departs very far from the Z_0 curve.

The methods of arriving at the corrected curves are too much to go into here. But we have found what I hope is an intelligible theoretical route, as well as a good short cut, to a performance curve for

the theoretical Z_0 -terminated filter; and when the sharp corner has been smoothed off slightly it makes a good enough design curve for an R-terminated filter.

If you are more interested in high-pass filters, all you have to do in Figs. 4 and 5 is to substitute $1/x$ for x .

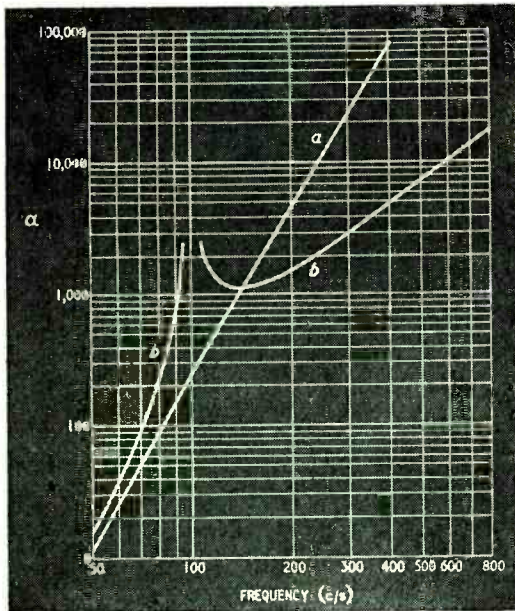

Fig. 6. The attenuation curves we had (Nov. 1949) for a typical smoothing system (b) with and (a) without choke tuning. This technique is elaborated in m-derived filters.

Fig. 7. One form of m-derived section corresponding to the simple low-pass T. An alternative is to put inductance in series with the vertical arm, to form an acceptor.

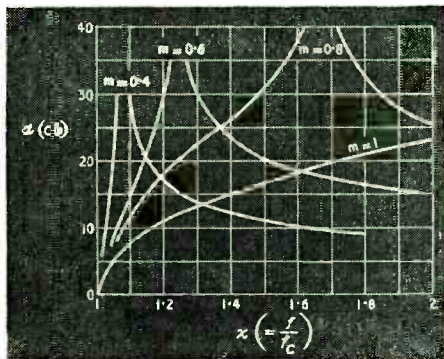
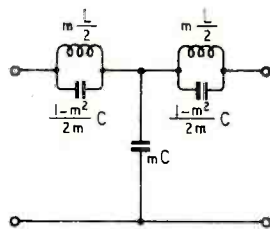

Fig. 8. How the attenuation curves of m-derived sections compare with that of the original "constant-k" (for which $m=1$). The cut-off is greatly sharpened at little extra cost.

There are any number of other types of filters (T. H. Turney defines a filter as *any* set of coils and condensers connected up anyhow, with input and output terminals). One of the most important is called the lattice, though it is exactly the same circuit as the Wheatstone bridge, drawn in such a way as to make it difficult to recognize. The only other one I have room to say anything about is a modification of the T and π types (collectively termed "ladder" filters). The basic types we have been concentrating on are sometimes called "constant-k" filters. That follows from a practice of denoting $\sqrt{Z_1 Z_2}$ in equation (1) by the letter k; as we have seen, in the case we considered, it is a constant for all frequencies, amounting to $\sqrt{L/C}$. It is, in fact, what we have been calling R. The same applies to the corresponding high-pass filters and also to band filters in which the series and shunt L's and C's are equal.

m-Derived Filters

There are two objections to constant-k filters. One is that their Z_0 varies so much over the pass band (Fig. 2). The other is that if you don't like the attenuation curve (Fig. 5) you have to lump it. Although you can multiply the α scale by using more sections, no adjustment of component values will make the cut-off per section sharper. So if you want to eliminate a frequency quite close to the cut-off with a constant-k filter you have to use an un-economically large number of sections, which may give far more attenuation at the remoter frequencies than you need. You may remember that three months ago we took note of a useful dodge for getting over this difficulty in the case of smoothing circuits using perhaps as few as two sections, by tuning one of them to reject the undesirable frequency. This dodge converted a rather gradual attenuation curve, (a in Fig. 6), into a really sharp cut-off with a peak at the frequency to be rejected (b). The fact that the attenuation at remote frequencies is less enormous doesn't usually matter.

In our smoother we just added capacitance across one of the chokes, sufficient to tune it to the offending frequency; and that was almost all there was to it. In filter books they dignify this simple modification with the title "m-derived filter" and devote a whole chapter to it, with several new lots of formulae. What is "m," and why? And what is all the fuss about?

Again, it is not really evidence of a "closed-shop" mentality. With the smoother, we didn't have to bother about what happened between the rejected frequency and zero. And (mainly for that reason) there was no question of matching impedances. But the sort of filter we are talking about now has to refrain from attenuating at all over a predetermined band of frequencies, and then cut off rapidly. To make it do this—and also to be able to predict the results with reasonable accuracy, and avoid mismatching—it is necessary to keep as close as possible to the ideal of working into and out of the characteristic impedance, Z_0 . It has been found that if, when the constant-k type of section is being modified into the tuned type, the L and C values are altered according to a set plan, it is possible to keep its cut-off frequency and its initial or nominal Z_0 (R) unaltered, so that the modified section will match the same load and also other modified or unmodified sections. No

only so, but its Z_0 can be made more nearly equal to R over the pass band, so going some way to meeting the other objection to the constant- k type.

The key to the plan is m , where m is the fraction by which the original arm impedances are multiplied or divided. The smaller m is, the closer the resonant frequency is to the cut-off frequency. When $m = 1$, there is no modification. I am not going into details, because anybody who is interested can look them up, and the rules are very easy to follow. Just as an example of the kind of thing, Fig. 7 shows how the original T section is modified into a "shunt-derived" T section, Fig. 8 shows how the value of m affects the position of the rejected frequency (f_r) relative to the cut-off frequency (f_c) (the formula is $m = \sqrt{(1 - f_c^2/f_r^2)}$), and Fig. 9 shows how m affects Z_0 . One can see from Fig. 9 that for keeping Z_0 as nearly constant as possible the best m is somewhere between 0.6 and 0.7, making f_c/f_r between 0.8 and 0.7, which may or may not be convenient.

Fig. 7 shows that the capacitance and inductances have been reduced to the fraction m of what they were, and two new capacitances have been introduced to tune the coils. This is not the simplest m -derived section to choose; my only reason is that it is derived from the type we have been considering most, so that (for example) Fig. 9 can be directly compared with Fig. 2. For simplicity one would choose the "shunt-derived π " (with only one tuned arm) or the "series-derived T" (with an acceptor circuit in the vertical arm). Another possibility is to use half a Fig. 7 section tacked on to a π (Fig. 3). If there are several different frequencies to be rejected, several derived sections can be used, each with a different value of m .

A good way of getting a grip of this introduction to filters is to work out the component values to meet

any requirements you may care to name. If you have the facilities for constructing filters from the resulting designs and testing them, that of course is the best way of all.

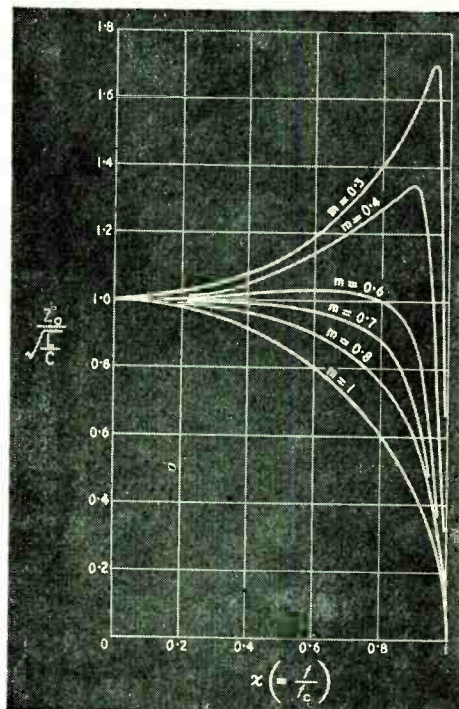

Fig. 9. Characteristic-impedance curves plotted for various values of "m" in Fig. 7.

Published Reports

Preferred Valves

Welcome example in limiting the bewildering number of valves at present in use has been set by the Scientific Instrument Manufacturers' Association, in publishing a list of preferred types for electronic instruments. The valves in each category have been chosen to give marked differences of characteristics, and whenever possible to have alternatives in this country or America; whilst in limiting base types, the aim has been to concentrate on International Octal for standard-sized valves and on B7G for miniatures. Characteristics and base connections are given in this booklet, which can be obtained from S.I.M.A., Ltd., 17, Princes Gate, London, S.W.7, price 2s 6d by post.

Tilts in the Ionosphere

Errors in direction finding at h.f. may be caused by lateral deviations from the great circle path of waves reflected from the F_2 layer. Radio Research Special Report No. 19, from the Department of Scientific and Industrial Research, ascribes this effect to random tilting of the layer at the point of reflection, and gives details of observations made with spaced-loop direction-finders on various h.f. broadcasting stations during 1938-1947. The report is published by H.M. Stationery Office, price 10d by post.

Marine Interference Suppression

A standard of interference suppression for ships is provided by a recently published British Standard (1597:1949), covering frequencies up to 30 Mc/s. It specifies the permissible limits of interference in terms of aerial terminal voltages, lays down conditions for the construction of wireless rooms and gives requirements to be satisfied by the ship's electrical machinery and wiring installation. There are also notes on the components used for suppression. B.S. 1597:1949 is available in booklet form from the British Standards Institution, 24-28, Victoria Street, London, S.W.1, price 4s by post.

Educational Film

"High Frequency" Heating, produced by Merton Park Studios, Ltd., for the British Electrical Development Association, is one of seven films which explain the fundamental principles of familiar electrical effects, and is designed for the age group 13 upwards. It runs for nine minutes and deals with both induction and dielectric heating, showing diagrammatically the process by which heat is generated in each case, and giving practical applications such as case-hardening drills and cooking a loaf of bread. The film, in 16mm. or 35mm., with teaching notes, is available on loan from the Association at 2, Savoy Hill, London, W.C.2.

UNBIASED

By FREE GRID

Radio-Rocket Racket

IT is now more than half a century since wireless was first used in warfare—field sets were taken by the Army to the Boer war in 1899. Range and reliability were—to use the jungle English of Whitehall—both in short supply and it is not surprising, therefore, that wireless played a very minor rôle in the campaign. It was, in fact, so minor that, as Mr. Churchill tells us, news of the customary early British disasters in warfare was signalled to his incoming ship by more reliable methods. It can be said without fear of contradiction that wireless had no influence whatever on the outcome of the Boer war, whereas on that of the next one it will be decisive.

I am not thinking so much of the radio-guided block-busters, which we may expect from Strelsau should we find ourselves in conflict with Ruritania, but of what I feel sure the popular Press will call "mercy missiles" in the shape of radio-controlled rockets containing food and all the other supplies which in the last two wars had to come to us over the submarine-infested seas.

In using these radio ration rockets for the dispatch of the meat, wheat and wool which we may expect from them, our friends in the Antipodes will, if, in the interests of fuel economy they choose a Great Circle route, obviously have to be careful to select the correct one of the alternatives available to them. If you will give Mercator a miss and plot on a *W.W.* Great Circle map the routes between us and the Antipodes you will see why. I speak with some feeling in this matter, for the last time I was "south of sixty" I found that some of the natives were



"South of Sixty."

no more friendly to this country than Commander Campbell's Patagonians and they might attempt, therefore, to deal with the rockets as the Ancient Mariner did with the albatross in these latitudes except, of course, that they would use micro-wave guns instead of a cross-bow.

I am laying some stress on the viewpoint that the beneficent rôle of radio rockets will far outweigh any "maleficence" (what a word!), because I think that the other point of view is, and always has been, over-emphasized in the Press and elsewhere; so much so that it is justifiable to call it a radio-rocket racket. As long ago as 1911 there was a display at Earls Court of model radio-controlled aircraft dropping radio-released bombs, and even this venerable journal, in its report of the matter, did not see fit to point out that the bombs might just as well have been sacks of ground-nuts or barrels of dehydrated beer. I would point out, too, that the radio-controlled rockets, which bring the much-needed manna, could, if necessary, be used on their return journey to evacuate the women and children.

I trust, therefore, that people will more and more realize that no matter whether we find ourselves in conflict with Ruritania or Erewhon, or at peace with all men, "radio is on our side" as it has always been.

Looking Ahead

WE are now well into 1950, but not in the second half of the 20th century, as so many people seem to think. It is perhaps scarcely surprising that they think so when the editor of one of our most widely circulated national "dailies" thinks so too, and has produced special editions to celebrate his error. I do not, of course, intend any reflection on his integrity, for editors are, above all, men of honour and wield the blue pencil mercilessly on anything they believe to be lacking in accuracy. Some of them, however, are a little weak in their arithmetic and, in the case of editors of specialist journals, also somewhat lacking in knowledge of matters outside their immediate ken, so that they accept without question statements made by their contributors.

A remarkable instance of this in the realm of radio occurred shortly before the opening of the Sutton Coldfield television station. Several

The opening ceremony in 1952.

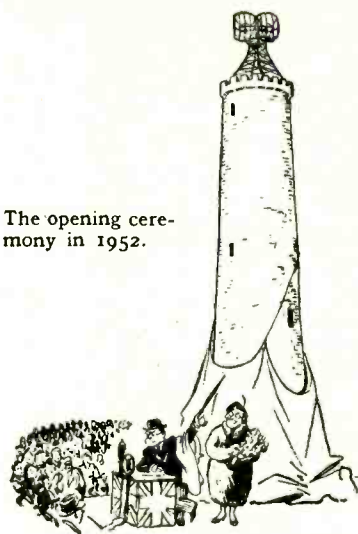

Midland newspapers, the editors of which had obviously never heard of d.c. television receivers, made the wild statement that residents in certain areas in the neighbourhood of the station would be denied television because of their lack of a.c. It is true that they were repeating words attributed to the chairman of the local Electricity Board, but surely editors know that the utterances of administrators on technical matters are often no more to be trusted than those of Mr Bevan on the treatment of chilblains.

Not only do some lay editors get their radio facts wrong, but they omit to bring to public attention things which cry out aloud for it. I refer more particularly to the fact that, so far as I am aware, not one single newspaper or periodical—including, I am sorry to say, *Wireless World*—has demanded the building of super-television studios on the south bank of the Thames after the shouting and the tumult of the 1951 Festival of Britain has died and its temporary pavilions are one with Nineveh and Tyre. A permanent concert hall is now being erected and a national theatre is planned, but these will take up only a small part of the space available. Surely, with such easy access to the West End, the site is ideal, in contrast to the proposed studios in the remote White City—also a relic of a bygone exhibition.

In addition, the famous Shot Tower is ideally situated for the necessary 30-centimetre link to be erected on top of it. Now is the time to demand this site before other interests stake their claim. In conclusion, I would stake my own claim to be invited to perform the opening ceremony in 1952; in this I have the full support of Mrs. Free Grid, who is, as a matter of fact, already trying to decide what she shall wear on the occasion.

Midget Three-Valve A.C. Mains Receiver

Adding Long Waves and a

Stage of Tuned R.F. Amplification to the Original Two-Valve Receiver

By S. W. AMOS, B.Sc. (Hons.), Grad.I.E.E. (Engineering Training Department, British Broadcasting Corporation)

THE article in the March, 1949, issue on a midget 2-valve a.c. mains receiver aroused much interest and the author has received many requests from readers for guidance in adding an r.f. stage, a long-wave band or both to the receiver. These requirements are met in the t.r.f. model described in this article; it is a 2-band receiver using EF50's in r.f., detector and output stages. The sensitivity is markedly superior to that of the 2-valve receiver and is such that worthwhile results can be obtained on signals of less than $100 \mu\text{V}$ amplitude; it should be adequate for reception of B.B.C. programmes in most parts of the country whereas the original 2-valve receiver was intended for use only near high-powered transmitters. The new receiver, illustrated in the accompanying photographs, is constructed on a chassis measuring $9\text{in} \times 5\text{in} \times 2\frac{1}{2}\text{in}$, the overall height being $6\frac{1}{2}\text{in}$. The 5-in diameter loudspeaker used with the new model is larger than on the original receiver and gives better quality. The total cost of the components for the new receiver is about £4 5s.

The circuit is given in Fig. 1; it has much in common with that of the 2-valve receiver and comparatively few additional components are necessary to modify the original set to the t.r.f. circuit. Tuning is by a 2-gang variable capacitor and the tuning inductors have standard values, commercial dual-

range coils (Denco type C) being used in aerial and intervalve circuits. To give high selectivity and to minimize the effects of different aerial constants on the first tuned circuit, shunt-capacitance aerial coupling is used, the low voltage gain of this form of coupling being largely offset by the high g_m of the r.f. valve. The primary windings of the aerial r.f. transformer are not used. The 470-ohm resistor R_1 is necessary to preserve d.c. continuity in the grid circuit of V_1 , and also to make the receiver input impedance low at 50c/s ; with a high value of R_1 , weak signals tend to be modulated at 50c/s .

EF50 valves are cheap and plentiful and because of their low heater consumption they are used in all stages of the receiver. The use of this valve as r.f. amplifier introduces a problem in controlling gain, because the EF50 is not a variable-mu valve, and whatever form of gain control is used must prevent overloading of the leaky-grid detector. The method finally adopted is shown in Fig. 1; a $50\text{-k}\Omega$ potentiometer is connected in the primary circuit of the intervalve r.f. transformer and the slider is taken to the anode of V_1 , this particular circuit being chosen to keep the damping of the detector tuned circuit constant, in spite of variations in gain setting. The gain control gives no protection against overloading of the r.f. amplifier but, of course, this receiver is

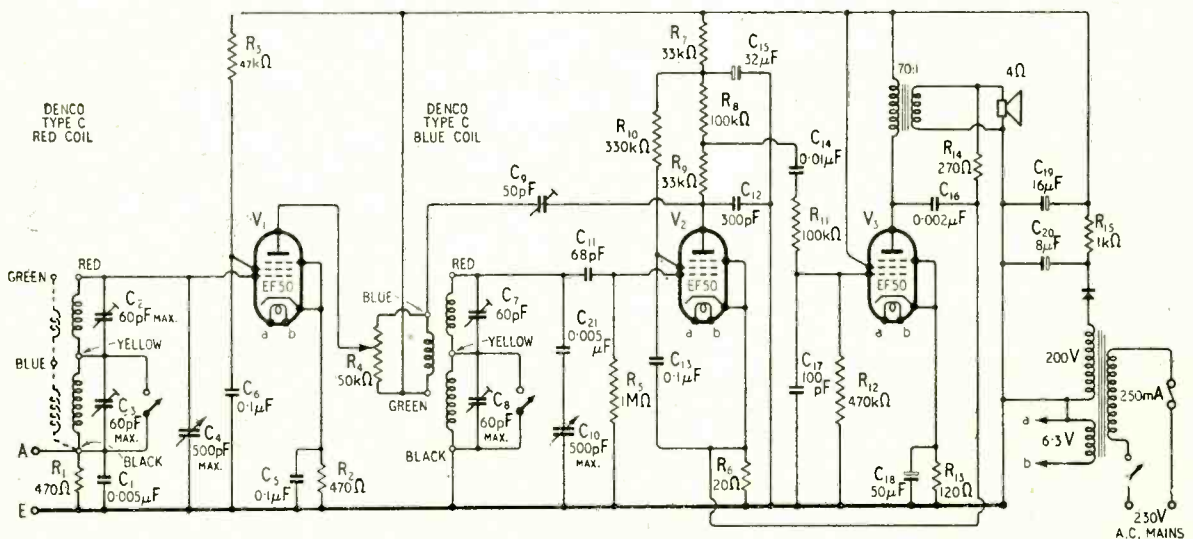
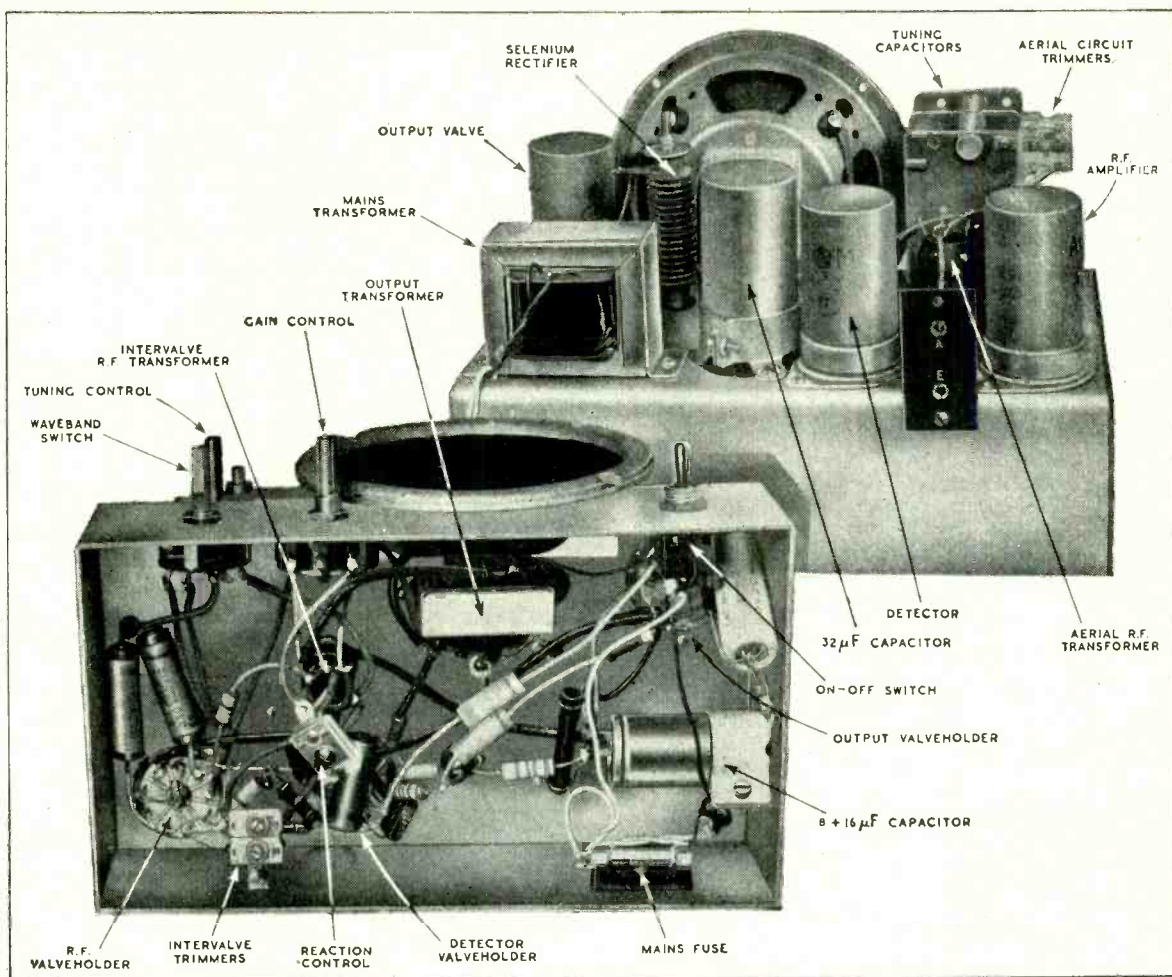

Fig. 1. Complete circuit diagram with component values. All resistors can be of $\frac{1}{2}$ -watt rating.



Two views showing the general layout of the receiver. To ensure r.f. stability the components in the grid circuit of the r.f. amplifier are mounted above the chassis and those in the detector grid circuit are located on the underside.

primarily intended for use in areas of comparatively low field strength. Nevertheless, the low voltage gain and high selectivity of the aerial circuit give good protection against overloading of V_1 and no symptoms of cross-modulation have been noted using the receiver within a few miles of a high-power transmitter.

Reaction is applied by a small pre-set capacitor; this should be adjusted well below the point of oscillation, but even so gives a useful improvement in gain and selectivity.

The $0.005 \mu\text{F}$ capacitor C_{21} is included to simulate the aerial-coupling capacitor C_1 and makes the effective tuning capacitance in the intervalve and aerial tuning circuits approximately equal, thus ensuring good ganging at the low-frequency ends of the wavebands.

When an r.f. valve is used in the output stage, particular attention must be paid to post-detector r.f. filtering, for even a small r.f. signal in the a.f. amplifier can mar reproduction. Three measures are used to suppress r.f. signals in this receiver: C_{12} shunts the anode load of V_2 and reduces the r.f. amplitude there; further attenuation is provided by

R_{11} and C_{17} ; finally C_{16} connected between the anode of V_3 and the cathode of V_2 gives considerable negative feedback at radio frequencies without affecting the performance at audio frequencies.

As the gain control operates in the r.f. section of the receiver, a fixed amount of voltage negative feedback can be used in the a.f. amplifier and is provided by R_6 and R_{14} . Fixed feedback is an advantage because it means that less h.t. smoothing is necessary for a given amount of hum; thus it has been found possible to reduce the value of the first smoothing resistor R_{15} from $5 \text{ k}\Omega$ in the 2-valve model to $1 \text{ k}\Omega$ in the 3-valve model, yet the hum of the new receiver is less than that of the original. By reducing the value of R_{15} the h.t. voltage is kept reasonably high (170 volts) in spite of the additional drain of the r.f. stage.

Apart from the alteration in the value of R_{15} the mains rectifying and smoothing components are identical with those used in the original receiver.

To align the receiver the trimmers C_2 and C_7 should first be set to their minimum capacitance and then advanced until a frequency of approximately 1,500 kc/s (200 meters) is received with the tuning capaci-

tors at minimum and the waveband switch set to medium waves. Finally, the trimmers should be accurately adjusted to give maximum output from the receiver on a signal near the high-frequency end of the medium-wave band such as the third programme on 1,474 kc/s. Trimmers C_3 and C_6 should be adjusted in a similar manner near the high-frequency end of the long-wave band, but on this band the trimmers should first be set at their maximum capacitance otherwise it may prove impossible to receive the low-frequency end of the band. The coil manufacturers (Denco, 355-9, Old Road,

Clacton-on-Sea) recommend a trimming capacitance of 70 pF for this band.

With many receivers the addition of an earth lead makes comparatively little improvement in reception, but with this receiver (and with the original 2-valve model) the addition of the earth lead makes a considerable difference, and it is recommended that a good earth connection be used whenever possible. Needless to say, a good aerial should also be used and it is perhaps worth stressing that the calibration and selectivity of this receiver are practically unaffected by the constants of the aerial used.

NEW BOOKS

Radio Aerials. By E. B. Moullin, M.A., Sc.D. Pp. 514+x1; figs. 243. Geoffrey Cumberlege, Oxford University Press, Amen House, Warwick Square, London, E.C.4. Price 50s.

THIS is the second volume in a new series of monographs describing recent advances in the scientific field. It deals only with a limited class of radio aerials, but does so in great detail.

The first section of the book is theoretical. The Lorentz vector and scalar retarded potential functions are first established and then applied to specific problems. These include the fields due to filaments, the effect of flat sheet and V-shaped reflectors, and problems relating to cylinders immersed in electromagnetic fields.

Some hypothetical problems are solved rigorously, usually in terms of Bessel functions, and practical problems are considered as approximations—usually very close ones—to the hypothetical cases. The power gain of typical arrays with various current distributions is calculated, and methods of suppressing the side-lobes discussed. A short section is devoted to the isolated aerial.

The remaining one-third of the book describes experimental procedure, and the results of measurements made on some of the aerials described in the first section. Results for V aerials are given in great detail, and include the radiation patterns for various V angles and sizes of sheet.

The reader who is interested in the practical applications of the aerials described, but does not wish to plod through the mathematics, will find plenty of interest in this section, and indeed throughout the book. From time to time the author draws attention to many practical design considerations—how far it is worth while increasing the size of sheet reflectors in order to improve the aerial performance, the permissible tolerance on the shape of the reflector, the use of netting and rods instead of continuous sheet, and similar problems of great importance to the aerial designer. The many examples of measured aerial performance will also be of interest—too little information has in the past been available, both in technical journals and in text books, on this subject.

The treatment is mainly mathematical, however, and the reader will require a reasonable knowledge of mathematics if he is to derive full benefit from this book. It will therefore appeal more to the aerial specialist or post-graduate student. A valuable feature of the book is that the author gives physical interpretations and justifications of his methods, which helps the reader to get the feel of the mathematics.

To sum up, this will be found valuable not only as a book of reference on the types of aerial covered, but also for the clear and logical development of the general theory.

H. P.

Industrial High Frequency Electric Power by E. May, B.Sc., A.C.G.I., M.I.E.E. Pp. 355+x1; figs. 208. Chapman & Hall, 37, Essex St., London, W.C.2. Price 32s.

MOST radio engineers look upon low-frequency alternators as a relatively unimportant part of their power supply equipment. This book leads them all the way from these low-frequency alternators up to the high-frequency oscillators which they are more at home with, and helps to present the whole subject as a single problem and, to give a new way of looking at it. It is interesting, for instance, to read of resonance as seen from the eyes of someone who has been brought up to believe it to be an evil thing, which an engineer can by his skill sometimes turn to his advantage.

The examples of equipment and applications in the lower frequency part of this field are well selected and authoritatively presented, and (once one has got over the shock of seeing a 400-cycle alternator called a "high-frequency alternator") can afford a valuable introduction to a subject which has been inadequately covered.

Readers of *Wireless World* will no doubt be more interested in the radio-frequency sections of this book. It must be regretfully said that in these the author is out of his depth. Is it true, for instance, that push-pull oscillators are more frequency-stable than single-sided oscillators? Is not there a risk that they will be more liable to parasitic oscillations? Has Mr. May never heard of parasitic oscillations? Does he really think that one of the reasons for coupled output circuits in high-frequency oscillators is to save d.c. drop in the tank circuit? Do arc oscillators produce damped waves? Spluttery and bubbly, perhaps, but are they damped? Is it necessary to spend a lot of time on idealized graphical solutions of oscillator performance including the usual simplified and quite erroneous load-line treatment only to reach conclusions which are either wrong or irrelevant (such, for instance, as the statement that the anode current is independent of grid drive as long as the grid bias remains constant)?

It is all a great pity; either as a text-book or a reference book about the lower-frequency end of the high-frequency heating problem this work is attractive and one would like to be able to recommend it to radio-frequency engineers as being complementary to their own store of knowledge. But the author has written a book which has one good and one bad half, and the bad half will discredit the good half in the eyes of so many people to whom it would have been useful.

A. H. C.

Book Received

Accumulator Charging. By W. S. Ibbetson, B.Sc., A.M.I.E.E. (Tenth Edition). Detailed treatment of the processes of charging, maintenance and repair. Pp. 190+xvii; Figs. 41. Sir Isaac Pitman & Sons, Parker Street, London, W.C.2.

Preferred-Value Attenuators

Choosing Suitable Resistors from a Limited Range

By
E. W. BERTH-JONES,
 B.Sc.

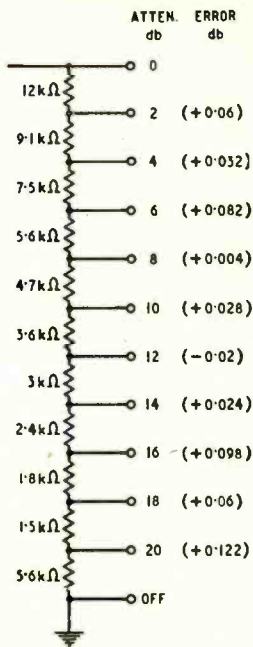

Fig. 1. Potentiometer giving attenuation of 1 db per stud, with maximum errors of -0.032 db and $+0.054$ db. Total grid-earth resistance is 47.3 k Ω .

IN audio engineering the demand often arises for a stepped attenuator in the form of a grid potentiometer, the steps giving equal increments of attenuation of one or more decibels. For many applications the accuracy, and hence the cost, of a commercially obtainable precision attenuator is not justified.

It is perhaps not generally realized that a very useful range of potentiometers can be constructed, using preferred-value carbon resistors and ordinary wafer type switches. The maximum possible error introduced by the preferred values can, for the purposes of computation, be broken down into two components: (a) a maximum standing error of about $+0.1$ db, representing the difference between the ideal calculated resistance and the nominal value of the nearest preferred resistor; and (b) an error representing the greatest deviation from the mean error of all the resistors used. To make (b) a little clearer, we will take an example. Supposing that we decide to use resistors of ± 5 per cent tolerance, we may find in practice that all the samples chosen fall between $+2$ per cent and $+4$ per cent of their nominal value. The mean error of the resistors is then $+3$ per cent, and the greatest deviation from this is ± 1 per cent, representing 0.09 db. So for this particular example we see that the maximum possible error in the attenuator, (a) plus (b), will be 0.1 db $+ 0.09$ db = 0.19 db, say 0.2 db. This assumes the worst case, of course, when both the components (a) and (b) are additive on the same resistor, and in general the actual errors encountered will probably be considerably less than this value.

With the figures quoted in the above example, the overall resistance of the potentiometer will be about 3 per cent above the designed value, due to the mean error in the resistors, but this fact is usually of no consequence. The first example is a potentiometer having a nominal resistance of 50 k Ω , suitable for working into a triode grid. Attenuation is provided in ten steps of 1 db, together with an "off" position.

The appropriate resistance values are as shown in Fig. 1, and it will be noticed that all the figures quoted appear in the list of preferred values. The total resistance works out at 47.3 k Ω , which is sufficiently near the nominal total of 50 k Ω for most practical applications. The resistors are assembled on a single-pole 12-way make-before-break wafer switch, which provides the click action usually desirable with step type attenuators. Obviously this selection of values is equally applicable in any decade, say, for a 500 - Ω or 500 -k Ω nominal potentiometer, but the values must not be transposed to give other totals.

Higher Values of Attenuation

Another example sometimes useful is a potentiometer giving attenuation of 10 db per step. Here each two steps give 20 db loss, a resistance ratio of 10:1, so that we require only two values, repeated as often as required in successive decades. Suitable figures are 68 and 22, with 10 between the lowest stud and earth, and a 100-k Ω potentiometer based on these numbers is shown in Fig. 2. The range of attenuation has been limited to 60 db because it is not practicable to exceed this value for normal applications, on account of the peak-signal/noise ratio of the following valve.

In this example it would be permissible to add an extra resistance of 220 k Ω at the upper end to give the potentiometer shown in Fig. 3, which has a total resistance of 320 k Ω . Note that the resistances at the lower end are not changed. Owing to Miller capacity

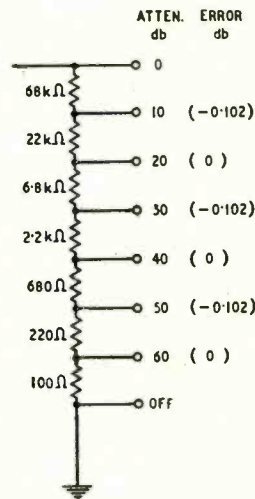

Fig. 2. Potentiometer giving attenuation of 10 db per stud, with a maximum error of -0.102 db. The total resistance is 100 k Ω .

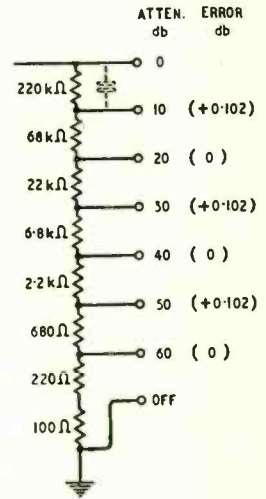
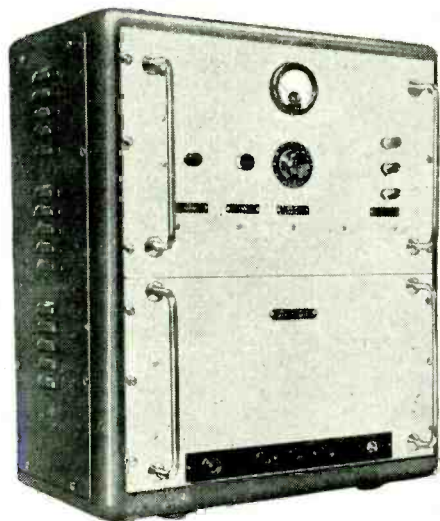

Fig. 3. Potentiometer giving attenuation of 10 db per stud, with a maximum error of $+0.102$ db. The total resistance is 320 k Ω .

Marine Communal Aerials

Ship's Distribution Systems Providing Interference-free Reception with Private Receivers



Communal aerial amplifier for the Redifon distribution system which is capable of feeding 300 private receivers from a single ship's aerial.

THE indiscriminate erection of aerials on board a ship by passengers and crew so that they can use their own wireless receivers at sea is frowned upon by the ship's officers, as, apart from being very unsightly, a host of small aerials can prove a serious source of error in the ship's direction-finding equipment.

A communal aerial is the only satisfactory alternative, but to be really efficient the system must be properly engineered. If an attempt is made to use a large number of receivers on a single aerial without certain precautions being taken many peculiar effects may be encountered. These can take the form of varying signal strength as receivers elsewhere are tuned over the broadcast bands; heterodyne whistles due to leakage of local oscillators into the distribution system; cross modulation; and, in the case of a ship, complete wipe out of all signals whenever the ship's transmitters come into operation. Some, if not all, of these troubles can also be experienced when separate aerials are used.

Several of the principal firms in the United Kingdom engaged in installing radio in ships have given this matter their attention and at

least two communal aerial systems, which allow trouble-free reception with private sets, have been installed in some of the larger vessels launched recently.

The system evolved by the Marconi International Marine Communication Co. consists of a main unit having three basic output circuits and this is augmented by supplementary units throughout the ship, which vary in number according to the size of the installation.

As it is possible to operate up to three receivers from each of the basic output circuits the main unit alone would serve a total of nine receivers. When more are needed, supplementary units are brought into use and, as each of these has six output circuits each capable of operating up to three receivers, a supplementary unit

will cater for eighteen sets. As the supplementary units provide amplification as well as circuit isolation there is no limit to the number of such units that can be employed.

The main unit, to which the aerial is connected, contains the necessary filter and rejector circuits to rid the broadcast signals of interference from the ship's transmitters. After these come a channel splitting stage then a three-channel amplifier. Each channel has a voltage amplifying stage and an output stage and is completely isolated from other channels.

A stage of amplification is used in the supplementary units and this feeds six separate output valves giving an adequate signal in all receivers over the 180- to 550-metre and 12- to 67-metre bands with small gaps as required to prevent interference from the ship's transmitters. There are no

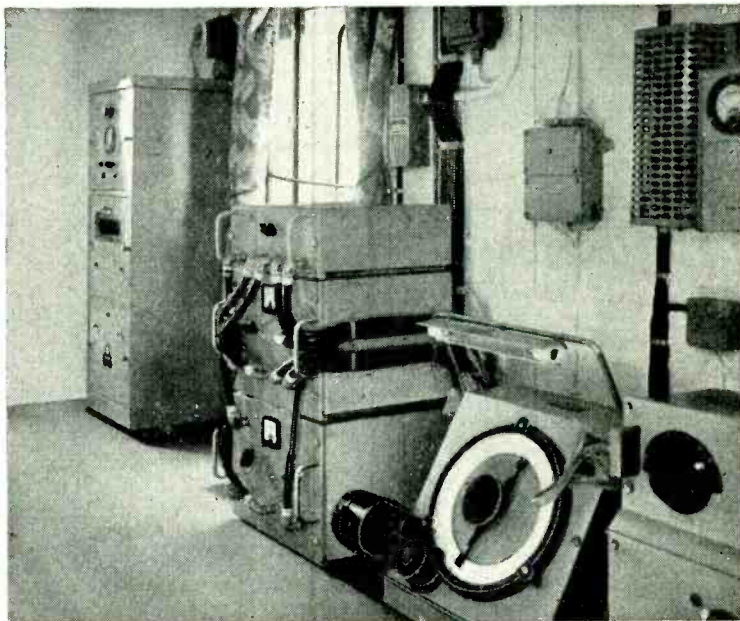

The Marconi communal aerial unit installed between the direction finder and the auto-alarm in the wireless cabin of the cable ship *Edward Wilshaw*.

filters in the supplementary units and all the rejection is effected in the main unit.

All units have self-contained power supplies and are available for either 110V or 220V d.c., or 230V a.c. The power consumption of each unit is between 60W and 110W according to the nature of the supply.

The system designed by Redifon provides optimum working conditions for about 300 receivers in the ship. Incoming signals from the aerial are fed via a cathode follower to two wideband amplifiers, one covering the medium- and long-wave bands, and the other the short-wave broadcast bands. The output from each chain is fed to a mix-

ing circuit and thence to three power stages each connected as cathode followers and feeding into separate output lines of from 70 to 150 ohms impedance. The receiving bands provided are 200 to 2,000 metres and 13 to 60 metres, with small gaps where necessary to reject frequency bands required for the ship's transmitters. This equipment is known as the Type A133.

At appropriate points in the system special junction boxes are fitted and in each cabin, or receiving point, is an outlet unit—for matching the receiver input circuit to the line—and the aerial and earth sockets. Isolating capacitors are included in these units so that under no conditions

can mains voltages get into the distribution system.

In the Redifon system all amplifiers, filters and rejectors are contained in a single unit which gives about 25 times overall amplification from the aerial to each of the output sockets. An a.c. power pack is also incorporated in the unit and the only external equipment needed, apart from the line apparatus, is a rotary converter to provide the necessary power when an a.c. supply is not available. The whole is housed in a sturdy metal case, measuring approximately 2ft 1½ in × 1ft 3 in × 1ft 9 in, and weighing 115 lb, and fitted with shock-absorbing bushes for bulkhead or desk mounting.

CONCENTRIC DUPLEX LOUDSPEAKER

A Compact Reproducer with a Wide Frequency Range

BASED on a design originally developed in 1935 by the Whiteley Electrical Radio Company, Victoria Street, Mansfield, Notts., the W/B Concentric Duplex loudspeaker is a small high-quality unit consisting of two moving coils working in separate gaps at either end of a powerful Alcomax III permanent magnet. One coil drives a horn-loaded "spherical" metal diaphragm and the other a 10-inch graduated-fibre cone diaphragm. The "tweeter" horn passes through the centre pole of the magnet and terminates in a non-resonant moulded bakelite flare.

Both coil drives have a pole diameter of 1 inch and the flux densities are 13,000 gauss in the tweeter and 12,000 gauss in the cone drive.

A multi-ratio transformer is fitted, and various combinations of high- and low-frequency matching are possible, since the low-frequency coil impedance is 3 ohms and the high-frequency, 30 ohms. To limit the excursion of the high-frequency diaphragm a 2-μF condenser is in series with the h.f. coil and transformer secondary.

We have heard this loudspeaker in operation and there can be little doubt that the makers' claim of a frequency range of 50 to 14,000 c/s can be substantiated. On the equipment used in the test there seemed to be an excess of medium-high frequencies, but this

could no doubt be adjusted by experiment with the matching arrangements. Indeed, it is the accessibility of the connections to the two units and the possibility of experiment with various matching alternatives, or the introduction of more elaborate cross-over filters, which will provide one of the chief attractions for the quality enthusiast.

On a plane baffle the Concentric Duplex gives a clean and full-bodied bass response of surprisingly good quality for a 10-in diaphragm. The diaphragm suspension is also of a type well-suited for use in conjunction with a cabinet of the "bass reflex" type if this is preferred.

The price is £6 6s complete with output transformer and condenser.

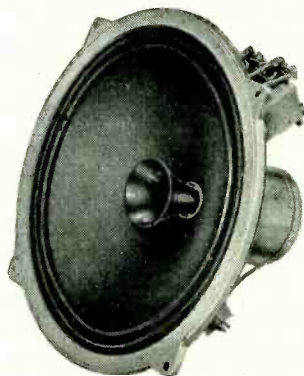

A non-resonant and non-magnetic die-cast frame is used to support the low-frequency cone in the W/B Concentric Duplex loudspeaker.

Responder Beacon

A 200-Mc/s beacon has been designed by Flight Refuelling Ltd., to assist their "tanker" aircraft to locate and intercept "customer" aircraft requiring fuel. It is carried by the "customer" and consists, basically, of a receiver and a pulse transmitter, arranged so that upon reception of an interrogating radar pulse from a Rebecca set in the "tanker," the receiver triggers the pulse transmitter, which radiates a reply pulse.

A notable feature is its long range, which is claimed to be 150 miles air-to-air; this is achieved with a

transmitter peak output power of 500 watts and pulses of 5- or 7-μsec duration. If required, the beacon will respond to interrogations from anything up to 25 aircraft.

An automatic coding unit is provided for identification purposes, and can be conveniently pre-set to give any combination of any three Morse characters. Either gap coding (keying the circuit) or pulse-width coding can be selected.

The power unit will operate on the ground from 110-240V mains, or from an 80-115V 1000-c/s aircraft supply.

LETTERS TO THE EDITOR

The Editor does not necessarily endorse the opinions expressed by his correspondents.

Radio Exports

I WAS very interested in the report given by the Commercial Secretariat of the British Embassy here in Tehran (p. 388, your October 1949 issue). So far as the published report goes it is correct but I should like to amplify it.

This country does not seem to be very important in the minds of British exporters of radio equipment, for they do not appear to have studied conditions sufficiently. It is in the interests of Britain that they should pay more attention, for Iran obtains its dollars from sterling; in fact the country can be considered as a "leakage" of Britain's dollars reserve. This "leakage" can be stopped by making British goods more attractive and less expensive than those obtainable from the American market.

How can this be done?

First by ensuring that importers are backed by a good sales and service organization. It is no use handing out agencies without first investigating whether the importer has the ability to sell and service the equipment. I can assure you that here in Tehran agencies seem to have been handed out indiscriminately.

It is realized that a great deal of responsibility must be placed in an agent's hands. The cost of providing a British representative for each firm would in most cases be uneconomical. Why not appoint representatives of the British Radio Equipment Manufacturers' Association to those countries which, as far as radio is concerned, are considered undeveloped? They could advise agents on the most up-to-date methods of demonstration, window display, advertizing, etc., and give lectures on servicing. In fact their job would be to provide a "welfare" organization for British radio equipment in each country.

My second suggestion is that exporters should undertake market research. In most eastern countries the populations can be separated into two sections, i.e., rich and poor. The poor outnumber the rich by ten to one; but who buys the present high-priced receivers? I leave you to answer. Now, what about the poor? All they want to listen to is their own station; no other station interests them. What they want is a small two-valve battery receiver, one waveband and, most important of all, low priced. I say battery,

because mains electricity is too expensive to install.

Surely a large manufacturing concern could turn out hundreds of this type of set cheaply, for, this problem not only concerns Iran but all other non-manufacturing countries where a large section of the population is poor.

Battery prices must also come down. A 120-V battery here in Tehran costs between three and four hundred rials (bank rate at present ninety to the pound). Something wrong somewhere!

As regards communication equipment, Iran has recently ordered a considerable quantity of American apparatus for airport installations. British equipment was far too expensive and even since the fall of the pound the prices are not equal. Of this I am assured by the radio engineer at the Tehran airport. Why can't British manufacturers get together and, instead of showing equipment at displays in England, go out and display it in the "wilds." On-the-spot demonstrations, even in miniature, with good advice thrown in, do more good than all the "at home" displays.

A. J. LIKEMAN,
(Radio Technician to
Imperial Iranian Air Force)

Tehran, Iran.

"Watering"

THE terminology of any branch of technology is important and so I would appreciate an opportunity to comment on your footnote reply to the query in my letter (January, 1950, issue) on the term "watering."

Three authorities on aspects of sound recording/reproduction, consulted independently, say that they have not heard of the term and it is certainly *not* widely used in film recording.

Apart from the accepted term "flutter," the colloquial and onomatopoeic term "wow" is certainly well known in the field, and the following terms are employed occasionally to describe various types of speed fluctuation: "wow-wows," "whine," "whiskers," "waver," "wobble," "gargle" and "drift."

The Sound Committee of the Society of Motion Picture Engineers in 1947 made an extensive study in an effort to reach standardization of flutter and wow terminology and measuring techniques, subsequently

TRIX

Quality SOUND EQUIPMENT

BATTERY OPERATED EQUIPMENTS



PORTABLE MODEL — B65
A completely self-contained low-power P.A. system.

This exceptionally compact equipment incorporates the amplifier complete with loudspeaker, rotary transformer, 6-volt unspillable accumulator, and microphone with cable, all self-contained in an easily portable case, and provides an output of approximately 5 watts.

The equipment forms a most useful outfit for political meetings, religious gatherings, auctioneers, etc., and numerous other applications where no electric supply mains are available.

Price Complete - - - £29 10 0

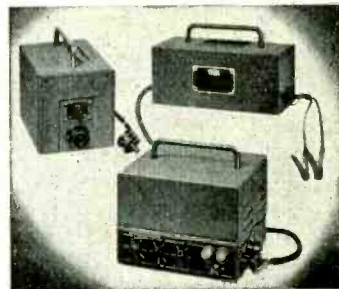

BATTERY — MAINS
Combined equipment Model B619

This model is designed for 12-volt battery operation and can also be used on AC mains by means of a separate plug-in adaptor unit. It operates with our standard moving coil microphones and various types of speakers are available for indoor or outdoor use. Power output when used on mains or batteries, approximately 16 watts.

Full details of these models and others in the large Trix range of equipment available on request.

Send for latest catalogues and price list.

THE TRIX ELECTRICAL CO. LTD.
1-5 Maple Place, Tottenham Court Road,
London, W.1. Phone: Museum 5817
Grams & Cables: "Trixadlo, Wesdo London."

AMPLIFIERS MICROPHONES LOUDSPEAKERS

publishing a long report on its findings (*Journal of the Society of Motion Picture Engineers*, Vol. 49, pp. 147-149, August 1947), but nowhere is the description "watering" mentioned.

Therefore, the derivation and any literature references containing this term that Mr. Berth-Jones can supply would be of great interest to me personally and, I am sure, to the B.S.I. Committee now working on sound recording terminology.

DONALD W. ALDOUS.

Torquay, Devon.

"American Hearing Aids"

I HAVE read with interest the article in your January issue and would like to correct the impression given concerning the newest miniature André-Yardeny type accumulator.

The writer of the article thinks this type of battery has not yet reached the stage where it can be safely entrusted to the public; this view is not shared by my company, who, having subjected these small accumulators to extensive tests over a period of some months, are satisfied that they can provide a reliable and economical low-tension supply for a hearing aid.

The Belclere Monomite P.3 instrument is now available with an accumulator for the l.t. supply, and a charger for the convenience of the user is provided. The accumulator, which costs 9s 6d, should, with ordinary care when recharging, give anything up to two years' service in the instrument.

O. C. LEADBITTER.

John Bell and Croyden, Oxford.

Academic Qualifications

I HAVE experienced some trouble in the past over this matter, and the following may be of interest to your readers.

I am a Graduate of the British Institution of Radio Engineers and hold the Full Technological Certificate of the City and Guilds. I applied some time ago to be placed on the Technical and Scientific Register, but was told that this was for persons with degrees and some professional qualifications, the I.E.E. being included but not the Brit.I.R.E. or the Full Tech. Cert. of the C. and G. I wrote to the Brit.I.R.E., who have been looking into the matter with the appropriate Ministry.

Your correspondent "Bunny" (January issue) may like to know that I obtained employment with the Ministry of Supply as an Assistant Experimental Officer. The rules regarding establishment specify "... B.Sc. ... or the five-year course of the C. and G. ..."

I am struck by the confusion that exists in the industry and the ministries regarding these various qualifications. I found it necessary when applying for posts to carry a copy of the various syllabuses about with me.

The confusion appears to arise concerning the following qualifications:—(1) Grad. Brit.I.R.E. (2) the old C. and G. exams, viz., Radio Comm. and Tech. Elec. 2. (3) The new C. and G. exams, viz., the Final Cert. and the Full Tech. Cert. The latter may include, for instance, Radio 1, 2, 3, 4, Telecomm. Principles 1, 2, 3, 4, 5 and Maths 1, 2, 3, 4, 5.

It appears to me that a real service could be done to young engineers about to start in the industry if the Brit.I.R.E. and the C. and G. could get together and circularize the various Ministries and private firms with a full statement of the position, giving exact details of the syllabuses etc., especially in view of the recent revision of the C. and G. course and their action in calling one of their group certificates "Final" when it is, in fact, followed by the Full Tech. Cert.

H. C. BERTOYA.

London, E.17.

"Easing Impedance Calculations"

I HAVE read with interest the article by M. G. Scroggie in your January issue on how impedance calculations can rapidly be made by

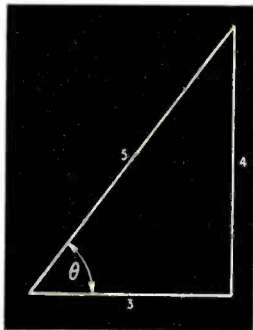

means of the slide-rule and a rearrangement of the original expression. You may be interested to know that for some years I have used a method of slide-rule operation which is almost the same as Mr. Scroggie's, but which may be slightly more simple in practice. This method is derived from the same source, namely, the well-known expression $1 + \tan^2\theta = \sec^2\theta$.

To calculate an impedance value, take the smaller value of either resistance or reactance and set it on the "C" scale to the left-hand index of the slide-rule. Slide the cursor

along to the larger value on the "C" scale. Read off on the "A" scale and add 1, sliding the cursor to this value. The resultant impedance is then indicated on the "C" scale.

The method may be proved by referring to my diagram of the familiar 3,4,5 right-angled triangle. If 3 on the "C" scale is set to the left-hand index and the cursor is moved along to 4, we get $4/3 = 1.33$, which is $\tan\theta$ on the D scale, and $\tan^2\theta = 1.778$ on the "A" scale. To this value 1 is added to give $\sec^2\theta = 2.778$ on "A" and $\sec\theta = 1.667$ on "D." Without further movement of the slide or cursor, $\sec\theta$ is automatically multiplied by 3, which gives the resultant impedance $3 \times 1.667 = 5$ under the hair line on the "C" scale.

ROBERT POLLARD.

London, S.E.26.

Pickup Design

I AM loth to take up more space, but James A. MacHarg's letter (your January issue) and wild statements cannot be allowed to go unchallenged. If he will re-read the article he will find that most of his letter need never have been penned.

I should point out, though, that if a pickup damages or distorts the record surface or groove in any way at all, it will be audible in the reproduction. Therefore a high-fidelity pickup that damages a record cannot be a high-fidelity pickup. Also many readers will know the Danse Macabre recording by Decca that is very popular as a demonstration record. A customer of ours, whose electrical and musical knowledge are beyond question, reports that during eight months' use of the pickup under discussion with a very good amplifier and loudspeaker system, he has played this record, among many others, over forty times without any signs of distortion. This, mark you, on the original sapphire.

T. S. MARSHALL.

London, N.1.

Pickup Damage

IN your December issue J. E. Ellis drew attention to the damage that can be caused to new records during auditions in the shop. Surely the solution is to buy, by post if need be, only from shops which use modern equipment properly.

It is still my view that minimum record wear is achieved with a good lightweight pickup using—dare I say it—miniature thorn needles. If such needles are carefully pointed they seem to be capable of giving reproduction aurally indistinguishable from a new sapphire, and at the same time will play a number of sides of 12-inch records without noticeable deterioration. The Decca "frrr"

gliding tone test record, for example, is quite reproducible at 13-14kc/s with these needles.

The thorn point is best used appreciably "sharper" than the normal sapphire point radius. Although this appears theoretically to involve an undesirable lack of "fit" in the groove, in practice no disadvantage appears to ensue. Mr. C. E. Watts' interesting report on the microscopic examination of records, also in your December issue, mentions that during a test, high-quality reproduction of gramophone records was found not to depend on continuous contact between the sides of the groove and the stylus point.

The reputed defects of thorn needles, namely, comparative pliability and rapid wear, seem much less significant when lightweight, lightly damped pickups with moving parts of low inertia are used.

As the above remarks are based on aural tests, I should perhaps say that my reproducer is a simple moving-coil pickup of my own design, amplified by a *W. W.* Quality Amplifier, feeding a high grade speaker in a reflex cabinet. I realize that such a.f. equipment is not up to the best modern "distortionless" standards, but the differences between the qual-

ity of current recordings seem to be incomparably greater than those between different types of good reproducers, and in my experience completely swamp them. These very wide variations in recording quality, even between the products of the same maker, are very puzzling.

A. M. POLLOCK.

Hatch End, Middlesex.

"Universal" Receivers

In your January issue L. Miller suggests series running of 1.4-volt 0.05-amp valves.

It is widely agreed that this practice is generally unsatisfactory, as filament breakdown becomes a frequent occurrence. This is due to the wide tolerance limits of 1.4-volt filaments which vary very greatly from valve to valve.

I have in mind one particular valve (type DAC32) used in a well-known a.c./d.c.-battery portable: it is not unusual to find 2 volts or more across its filament pins with a consequent drop across the filament pins of the remaining valves in the series chain. Very frequent replacement is found to be necessary.

W. G. EVERSLED.

Gomshall, Surrey.

CLUB NEWS

Birmingham.—At the meeting of the Slade Radio Society on February 17th, M. Moston, of the Winter Trading Co., will speak on "Television Components for the Home Constructor." On the 18th members will be visiting the Birmingham Police Radio Headquarters. Meetings are held on alternate Fridays at 7.45 in the Parochial Hall, Broomfield Road, Erdington. Sec.: C. N. Smart, 110, Woolmore Road, Erdington, Birmingham, 23.

Birmingham.—At a recent meeting of the Radio-Controlled Models Society the Birmingham Area Group was formed. Details of forthcoming meetings are obtainable from the secretary, G. F. Golding, 32, Beechfield Road, Smethwick, Staffs.

Cleckheaton.—At the meeting of the Spen Valley Radio and Television Society on February 1st, H. Clegg (G3FX) will deal with "Unusual Aerials." Meetings are held fortnightly at 7.30 at the Temperance Hall, Cleckheaton. Sec.: N. Pride, 100, Raikes Lane, Birstall, Nr. Leeds.

Enfield.—Meetings of the Enfield Radio Society are now held in St. James' Hall, Durants Road, Ponders End, at 7.0 on Mondays. Sec.: F. A. Ticknell, 10, Cowdrey Close, Enfield.

London.—The next meeting of the London Area Group of the Radio-Controlled Models Society will be held on February 12th at 2.0 at the St. Ermin's Hotel, Victoria, London, S.W.1. Sec.: Lt. G. C. Chapman, Pine Corner, Heathfield, Sussex.

Southall.—A lecture on "Multi-vibrators" will be given by H. K. Winwood to members of the West

Middlesex Amateur Radio Club on February 8th. Meetings are held on the second and fourth Wednesdays of the month at 7.30 at the Labour Hall, Uxbridge Road, Southall. Sec.: H. C. Bostock, 1, Grange Road, Hayes.

Southend.—Exhibits for the Pocock cup which is awarded annually to members of the Southend and District Radio Society for home-constructed equipment will be judged on February 24th. Sec.: J. H. Barrance, M.B.E. (G3BUJ), 49, Swanage Road, Southend-on-Sea, Essex.

Speke.—The recently formed Speke Radio and Television Society now meets on Fridays in the Stockton Wood Road School. Sec.: H. Timms, 101, Western Avenue, Speke, Lincs.

Sunderland.—The chairman of the Sunderland Radio Society, R. V. Duesbury (G3CTE), will address members on "Sensitive Relays" at the meeting on February 8th at 8.0 at Prospect House, Prospect Row, Sunderland. Sec.: C. A. Chester, 38, Westfield Grove, High Barnes, Sunderland.

Whittington.—The recently formed Whittington Radio Club meets each Wednesday at 7.0 in the Angel Inn Club Room, South Street, New Whittington. Sec.: W. Watson, 44, Handley Road, New Whittington, Chesterfield, Derbyshire.

British Amateur Television Club.—The purpose of this club is to encourage activity by amateurs in television. Particulars of the club, which issues a duplicated magazine called "CQ-TV," are obtainable from M. Barlow (G3CVO), Cheyne Cottage, Dukes Wood Drive, Gerrards Cross, Bucks.

ANTIFERRENCE 'Fourway'

The
VERSATILE

TV AERIAL for
STRONG SIGNAL AREAS
FOR INDOOR USE

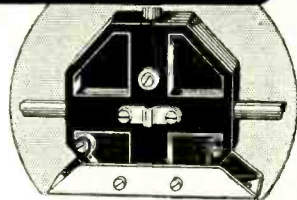

ONE TYPE FOUR WAY

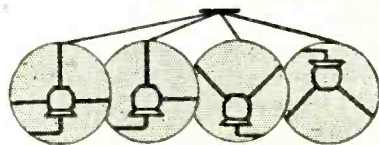

FOR OUTDOOR USE

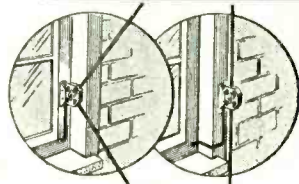

WHEREVER signal strength permits the use of an indoor aerial, the "FOURWAY" has proved itself by fulfilling every demand of the most critical. Its adaptability to widely varying structural requirements enables the "Fourway" to be mounted in the loft or unobtrusively in any part of the house. Although originally designed for indoor mounting, the "Fourway" gives even better performance when mounted outdoors (as illustrated) and is the ideal aerial for flat dwellers and those who find that an indoor aerial provides insufficient signal strength. Suitable for use with every type of television receiver and feeder cable.

LIST PRICE { London Transmission—Model 4-way/L
Midland Transmission—Model 4-way/B

25/-

ANTIFERRENCE
LIMITED

67 BRYANSTON ST · LONDON W.1

RANDOM RADIATIONS

By "DIALLIST"

The Clash of Symbols

AN EMINENT READER of *W.W.* sheds light on the reason why in some French publications batteries appear in circuit diagrams with short, fat positives and long, thin negatives. This arrangement, he tells me, was widespread on the Continent until a certain international conference was held. The British delegates stuck out for the "thin plus"; but one or two European parties refused to play unless they received something in exchange for their acquiescence. After much thought, our people agreed to make the British symbol for a slow-to-operate relay conform to Continental practice, and honour was satisfied! The position now is that, officially, all European countries have adopted the familiar long, thin line for positive and short, thick line for negative. Some publications, however, prefer to assert their individuality by using fat pluses and thin negatives. Another eminent correspondent mentions that books produced in this country are not wholly guiltless of befogging their readers by misusing the battery symbols. In one fairly recent work all the circuit diagrams show h.t. and l.t. batteries apparently connected the wrong way round! Seems a pity, doesn't it, that we can't achieve unanimity on even so

simple a point as this. My sympathies are all with the sorely tried beginner who, having mastered the symbols used in his first book, finds that in the next one he tackles they have just the opposite meanings.

Useful Tip

One of the readers mentioned in the preceding paragraph sends me a convenient way of remembering the polarity of a rectifier as represented in a circuit diagram by its conventional symbol. By "polarity" is meant that of the battery which could be substituted in a power circuit for the rectifier. Here's the tip: Draw the symbol for a single cell, with thin positive and fat negative poles. Whilst thickening-in the negative, permit yourself to indulge in a little mild doodling and shape it into a triangle. The cell now becomes a rectifier with the polarity correctly shown. There's not, of course, any real need to do the doodling. All you have to remember is that in the symbols for cell and rectifier the thin element is the positive and the fat one the negative. That is, naturally, so long as either symbol is correctly used.

Sutton Coldfield

ONE OF THE STRONGEST impressions left by a walk round the

Sutton Coldfield transmitting station is of the neatness of its layout and design. There's no wasted space and no overcrowding. The outside of the building can't be described as beautiful, for it is distinctly severe in style. Nevertheless, it is pleasing to look at because its design is functional. A great deal of thought, clearly, went into making the interior of the world's biggest television station as labour-saving as possible from both the engineers' and the cleaners' points of view.

Teething Troubles

An emergency occurred at Sutton Coldfield at a moment which Fate, in one of her most pernicky moods, must have selected specially to bring home to mortal man that he still can't say with certainty, "At such and such a time I shall do this or that." A second or two before the station was due to make its much-heralded opening transmission there was an arc-over in one of the CAT₂₁ triodes of the output stage of the transmitter. The valve didn't "blow up," as was suggested by some lay publications. It was back in service within ten minutes and, so far as I know, it is still doing its stuff. There have been other breakdowns since—in fact Sutton Coldfield has had more than its share of bad luck in this way—but all have been speedily dealt with.

Stand-by Apparatus

One could, of course, guard against the consequences of almost any kind of breakdown by duplicating every stage of the transmitter and by providing automatic switching arrangements to bring stand-by apparatus instantly into use when this part or that of the normal gear went "phut." When I expressed a certain wonder that duplication hadn't been carried further at Sutton Coldfield, it was pointed out that other parts of the country would take a rather poor view of the B.B.C. television development policy if it installed as stand-by apparatus at Sutton Coldfield bits and pieces that should be part and parcel of the main transmitters in other regions. I hadn't quite realized that, whatever its purchasing power, the B.B.C. must take its allotted place in the long queue of those seeking to acquire equipment. That being so, Sutton Coldfield "Paul" could not be equipped with complete stand-by gear without robbing of their birthright the unborn "Peters" in eagerly awaited new



"WIRELESS WORLD" PUBLICATIONS

	Net Price	By post
RADIO VALVE DATA. Characteristics of 1,600 Receiving Valves	3/6	3/9
RADIO DATA CHARTS, by R. T. Beatty, M.A., B.E., D.Sc., Fifth Edition—revised by J. McG. Sowerby, B.A., A.M.I.E.E.	7/6	7/11
GUIDE TO BROADCASTING STATIONS. Fifth Edition	1/6	1/7
BASIC MATHEMATICS FOR RADIO STUDENTS, by F. M. Colebrook, B.Sc., D.I.C., A.C.G.I. Second Edition	10/6	10/10
RADIO LABORATORY HANDBOOK. Fourth Edition, by M. G. Scroggie, B.Sc., M.I.E.E.	12/6	12/11
TELEVISION RECEIVER CONSTRUCTION. A reprint from "Wireless World" (London area only)	2/6	2/9
SUPERHETERODYNE TELEVISION UNIT. A reprint from "Wireless World"	2/6	2/9
WIRELESS DIRECTION FINDING. By R. Keen, M.B.E., B.Eng.(Hons.), Fourth Edition	45/-	45/9

A complete list of books is available on application

Obtainable from all leading booksellers or from

ILIFFE & SONS LTD., Dorset House, Stamford Street, London, S.E.1.

television service areas. And even as a child one learnt to appreciate what happened when birthrights were bartered away. I could at this point perpetrate a joke about Esau and 'E didn't see—but I refrain.

Signs of the Times?

THE OTHER EVENING I had a telephone call from a friend who lives nearby. Rather diffidently, he asked whether there had been anything in the six o'clock news about something or other—what, exactly, it was I don't remember, though it was, no doubt, very important at the time. "Your wireless set misbehaving?" I asked, when I'd given the desired information. "As a matter of fact," he said, "we haven't a wireless set now." He told me, rather sheepishly, that they'd found just before Christmas that the old wireless set was on its last legs. To recondition it would have cost more than it was worth. They had decided to have a new receiver when their eldest young hopeful pointed out—and kept on pointing out—that it wouldn't cost all that much more to have a television set. Having at length given way to his entreaties, they were now discovering with no small chagrin that the television can supplement the wireless set, but certainly cannot replace it. I'm hoping that the epidemic won't spread to others of my friends, for I get quite enough telephone calls as it is. And am I acting strictly within the terms of my receiving licence if I "publish" the gist of broadcast programmes over the telephone to inquirers?

SOLDERING ALUMINIUM

ONE of the reasons for the difficulty of soldering aluminium is its affinity for oxygen and the fact that in air a thin transparent film of oxide forms on the surface immediately after cleaning.

To disrupt this film continuously and thus expose the pure metal to the action of the solder, Mullard Electronic Products, Century House, Shaftesbury Avenue, London, W.C.2, have developed soldering iron (Type E7587), in which the bit is maintained in ultrasonic vibration by means of a magnetostriction transducer powered from a valve oscillator unit. The bit is heated by a conventional resistance winding and of the normal copper type.

Solders with a tin-zinc base are recommended and no flux is required. Ordinary tin-lead solders can be used, but may give rise to subsequent electrolytic corrosion.

Quality ELECTRONIC COMPONENTS

FAMOUS ALL OVER THE WORLD

THE EXPERIENCE OF 25 YEARS
BEHIND EVERY COMPONENT

NEW PRODUCTS OF INTEREST



List No. P.440



List No. F.155



List No. C.R.21

List No. P.440—New valve-top connector of modern appearance and design. Moulded in RED or BLACK. "Standard" base.
List No. P.441—"Octal" base version.

List No. F.155—New moulded panel-mounting 1-pole fuseholder for Bulgin "PAK" and all 1/4" dia. x 1 1/2" cartridge fuses, which select with bayonet-engaging vibration-proof front knob.

List No. C.R.21—New croc. clip for gripping fine wire without damaging it. Shown open to demonstrate special jaws. Nickel-plated.
List No. C.R.23—Brass, self-finish version.

NEW SWITCHES

List No. S.450—Small rotary button-knob switch in polished plastic. Offers continuous "On-Off" Right-hand rotary action.

List No. S.451—New moulded type for all 24v. max. circuits. Snaps ON, and OFF, with a click. Silver-plated contacts.

List No. S.264—Popular 1-pole C-O switch, for all 0-250v., 2A max. circuits. Guaranteed—like all BULGIN switches—for at least 25,000 operations.

List No. S.220—Push-pull 1-pole M-B action; pull for OFF. For 6A at 0v., 4A. at 110v., and 3A. at 250v. circuits. Polished plastic knob unacrews for mounting.



List No. S.451



List No. S.450

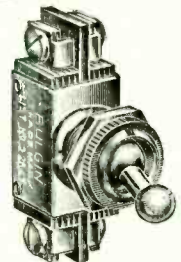

List No. S.264

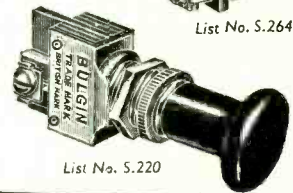

List No. S.220

DISTINCTIVE MOULDINGS

These famous BULGIN knobs are of distinctive design and greatly enhance the appearance of all apparatus. Those shown are but a few of the many models illustrated in the BULGIN CATALOGUE. All are designed for firm grip and accurate adjustment, and are fitted with a hardened and well-sunk 4 B.A. grub screw for standard 1/4" dia. shafts. Normally finished in highly-polished BLACK, with white-filled "hair-line". This range includes some of the most popular BULGIN components.

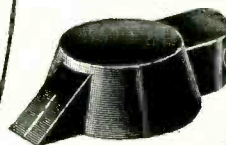

List No. K.58



List No. K.324



List No. K.111



List No. K.18



List No. K.6

EVERY COMPONENT GUARANTEED

SEND FOR NEW ILLUSTRATED CATALOGUE 1/- post free

BULGIN

A. F. BULGIN & CO. LTD.
BYE-PASS ROAD, BARKING
Telephone: R1Ppleway 3474 (5 lines)

Manufacturers' Products

New Equipment and Accessories for Radio and Electronics

Checking Mobile Equipment

TWO useful pieces of v.h.f. test apparatus for tuning and checking mobile radio installations have been introduced by Mullard Electronic Products, Century House, Shaftesbury Avenue, London, W.C.2. One is a radiation monitor (Type GME₅₀₁/X) consisting of a current transformer and crystal rectifier housed in an insulated case with a centre hole attached to a long handle, which, when slipped over the whip aerial used on vehicles and "Walkie-Talkies," gives a measurement of aerial radiation.

The actual indicator is a separate 0-500 micro-ammeter, which is used also with the other item, an r.f. tuning indicator (Type GFE-506/X). Basically it consists of a short length of concentric line, which is inserted in the aerial feeder at the transmitter end. The line incorporates an r.f. probe and rectifier and measures the voltage on the inner conductor without disturbing the impedance of the line.

This unit is housed in a metal box and is fitted with co-axial sockets for the feeder and plain

sockets for the meter connections.

Both indicators can be used with transmitters up to 20 watts output and for frequencies of from 65 to 200 Mc/s.

The aerial monitor costs £3 19 6 and the tuning indicator £2 17 6. The price of the micro-ammeter is £6 13 6.

Television Pattern Generator

MANUFACTURED by Murphy Radio, this television pattern generator, Type TPG11, provides an r.f. output modulated with a test pattern and sync pulses conforming to the B.B.C. waveform. It therefore enables a receiver to be adjusted in the absence of any transmission so that subsequently it needs nothing beyond the proper setting of the contrast control for proper reception. It should thus be of great value to dealers who can install and adjust sets with its aid outside the hours of television transmission.

On the r.f. side, the generator consists of an oscillator covering 40-70 Mc/s and an amplifier which is suppressor-grid modulated by the required waveform. The output is taken through a 10-db-step ladder attenuator and a continuous control to a coaxial cable. The r.f. output is of the order of 40 mV maximum and up to 65-db attenuation is provided.

The output can be unmodulated, modulated with a 250-c/s square wave or modulated with sync pulses and a pattern. These waveforms are generated by a series of multivibrators and flip-flops which start with a 20,250 c/s multivibrator. Correct frequency is ensured by locking to the mains frequency.

The pattern produced consists of

four equally spaced horizontal black bars and one broad vertical black bar. In addition, there are some 26 very narrow vertical grey bars.

Because the sync waveform is correct, a receiver can be adjusted for proper interlace and aspect ratio, while linearity can be adjusted by setting the controls for equal spacing of the pattern bars. By setting the r.f. output at the value corresponding to the field strength in the area, even the contrast control can be set approximately.

The test pattern waveform and the sync pulses are available for video testing and test sockets are provided in case adjustments to the instrument are needed. The generator weighs 30 lb and the power unit, which is separate, 20 lb. The approximate overall dimensions are 18½ in tall by 12½ in by 12 in for the generator and 12 in by 7 in by 7½ in for the power unit. It costs £140 and is sold by F. Livingstone Hogg, 65, Barnsbury St., Islington, London, N.1.

MANUFACTURERS' LITERATURE

CATALOGUE (No. 180) of radio components from A. F. Bulgin & Co., Bye Pass Road, Barking, Essex.

Synopsis of "Cintel" electronic instruments for research and industry from Cinema-Television, Ltd., Worsley Bridge Road, Lower Sydenham, London, S.E.26.

Catalogue of H.M.V. television receivers for the Midland transmitter frequencies, and an illustrated leaflet describing the Model 2103 automatic record player, from the Gramophone Company, Hayes, Middlesex.

Folder giving list of "Somerford" transformers and chokes, including components specified in the Williamson High Quality Amplifier, and a brochure of audio output transformers, from Gardners Radio, Somerford, Christchurch, Hants.

Data sheet of Marconi receiving valves from the Marconiphone Company, Hayes, Middlesex.

"Industrial Photocells"—a 20-page booklet of data on vacuum and gas-filled types, with circuit recommendations—from Mullard Electronic Products, Century House, Shaftesbury Avenue, London, W.C.2.

Illustrated leaflets describing the Type D-365-A; Duddell oscillograph; Type A-181-A inductance bridge; Type D-101-A frequency bridge and a universal unit conductivity bridge, from Muirhead & Co., Beckenham, Kent.

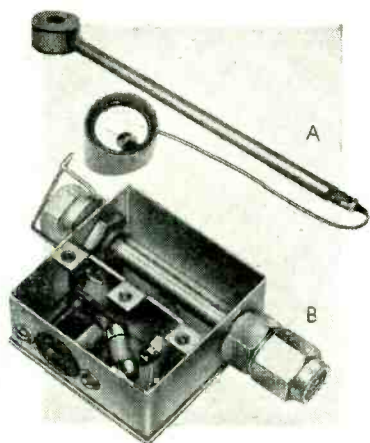

The Mullard radiation monitor with micro-ammeter is shown above at A, while B depicts the tuning indicator with its cover removed.

Murphy Radio television pattern generator with its power unit.

